

A Method for Generating MRI Cardiac and Respiratory Gating Pulse Simultaneously based on Adaptive Real-Time Digital Filters

HD Park¹, SP Cho¹, KJ Lee^{1,2}

¹Yonsei University, Wonju, Korea

²Center for Emergency Medical Informatics, Seoul, Korea

Abstract

In magnetic resonance imaging (MRI), imaging a moving organ such as the heart requires a trigger so that successive scans can be synchronized. In the case of cardiac and respiratory imaging, the QRS complex of ECG is used as a trigger signal for MRI scan. But, gradient and radio frequency (RF) artifacts which are caused to static and dynamic field in MRI scanner cause interference in the ECG. Also, the signal shape of these artifacts can be similar to the QRS-complex, causing possible misinterpretation during patient monitoring and false gating of the MRI. In case of using general FIR or IIR band-pass filters for minimizing the artifacts, artifact-reduction-ratio is not excellent. So, an adaptive real-time digital filter is proposed for reduction of noise by gradient and RF artifacts. The proposed filter for MRI-cardiac and respiratory gating is based on the noise-canceller with normalized least mean square (NLMS) algorithm. The reference signals of the adaptive noise canceller are a combination of the noisy three channel ECG signals. In conclusions, the proposed method showed the acceptable quality of ECG and respiration with sufficient SNR for gating the MRI and possibility of real time implementation.

1. Introduction

Magnetic resonance imaging (MRI), a clinically important medical imaging modality, provides biomedical, anatomical, and functional information of biochemical compounds within any cross section of the human body.

When imaging the heart using MRI, a clean and artifact-free electrocardiograph (ECG) signal is not only important for monitoring the patient's electro-magnetic heart activity and heart rate, but also for cardiac gating.

Because conventional MRI images are formed from a number of repetitions of a sequence, imaging a moving organ such as the heart requires that each sequence be triggered at the same part of the cardiac cycle. Several different triggering techniques can be used, including finger plethysmography and carotid pulse tracings, but the most widely used trigger is the ECG [1].

A fundamental problem associated with using the conventional ECG to monitor a subject's cardiac activity during MRI is the distortion of the ECG due to electromagnetic interference. ECG signals are heavily disturbed by various phenomena such as static magnetic field interference and magnetic gradient related interference.

To make us more miserable, present MRI techniques strive for improved spatial and temporal resolution performances. In the past, various strategies have been proposed to make ECG recording possible in the MR environment [2-8].

The aim of this work is to extract an efficient reference signal in real-time, from an ECG that was contaminated by the MRI artifacts. digital signal processing (DSP) technology allows additional flexible adaptive filtering to further improve the output ECG waveform. Recently, a suppression method of MR gradient artifacts which are based on an adaptive real-time filter using adaptive noise canceller (ANC) is suggested [9]. But, that paper used gradient pulse signals (Gx, Gy, Gz), acquired from gradient amplifier of the MR scanner, as reference signals.

In this paper, we applied adaptive noise cancellation filter (ANCF), a simple and robust digital signal processing method for gradient noise reduction on ECG signals acquired during MR sequences.

The coefficient update algorithm of ANCF is normalized least mean square (NLMS) algorithm. Also, the proposed ANCF need not gradient pulse signals (Gx, Gy, Gz), acquired from gradient amplifier of the MR scanner, as reference signals. The reference signals of the adaptive noise canceller are a combination of the noisy three channel ECG signals. Therefore the proposed method has advantage which is performed independently with the MR scanner. This may be used for MRI gating pulse and/or monitoring cardiac rhythm and respiratory rhythm.

2. Methods

2.1. Instrumentation

The experiments were done on a 0.5T MRI system (AI

Lab., South Korea). The ECG data were collected with preamplifiers and analog band-pass filters through four carbon electrodes (biopac inc., USA) with a sample rate of 1 kHz. The gain of preamplifiers is 500 and the bandwidth of analog filter is 1–150 Hz. Also, the data acquisition system was located in a shielded box. And, the carbon electrode leads — 1 mm thin and 200 cm long coax cables — were bundled together and firmly fixed. Precaution was taken not to put any loops in the leads. Next, they were attached to the inputs of the ECG preamplifier just outside the magnet’s bore. The amplified signal was then carried over a fiber-optic cable to the PC.

The software used for measuring, displaying, and analyzing the signal was the Labview 7.0 (NI, USA). The software for filtering the data has been the Matlab 7.0 (Mathworks, USA). The block diagram of measurement system is shown Fig.1.

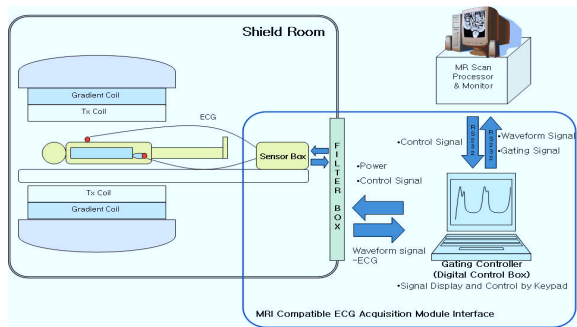

Figure 1. The block diagram of measurement system

2.2. Experimental procedure

As to validate the performance of the proposed method, knowledge of the MR gradient artifact free ECG signal is required, because only in that case, the residual signal after restoration can be analyzed.

In this way, the recording conditions were made identical compared to a normal experiment (electrode positions, etc.) while, of course, recording no ECG signal (or movement related artifacts) at all. Hence, only artifacts related to the MR gradient switching were recorded.

Various imaging sequences were applied such as Spin Echo (SE), Fast Spin Echo (FSE) and Gradient Echo (GE), with various echo (TE) and repetition times (TR). These recordings took for 1 minute in each sequence. The artifact recordings were then superimposed onto ECG signals from humans, which were acquired without MR imaging. Next, to these artificially corrupted data, the proposed filtering scheme was applied.

2.3. MR gradient artifacts reduction method

The voltages induced by the MR gradient produce artifacts that are added to the electrophysiological signal. The simplified model of gradient artifact generation is shown in Fig.2.

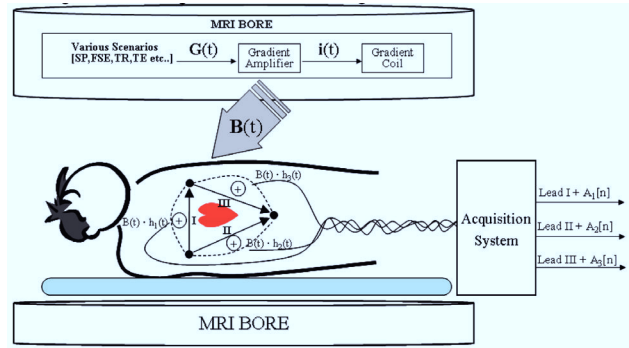

Figure 2. The simplified model of gradient artifact generation

Eq.1 represents the generated gradient artifact

$$A[n] = f(\vec{B}(t)) \approx -\frac{d\phi}{dt} = -\frac{d(\vec{B} \cdot \vec{A})}{dt} = -\frac{d((\vec{G}(t) \cdot \vec{r}(t)) \cdot A(t))}{dt} \dots \text{Eq.1}$$

where $A[n]$ is the gradient artifact included in the ECG as a result of varying the MR gradient, $B(t)$ is the magnetic field in the MR bore, $G(t)$ is the vector containing gradient signals, $r(t)$ is the coordinates of the MR bore where induction occurs, and $A(t)$ is the active area where the magnetic flux flows through the human tissue, lead wires, and the ECG electrodes.

In our research, we took advantage of the ‘three lead vector system’ within the ECG. We reconstituted the signal with only the artifact of the perfectly removed ECG signal. In ECGs, “Lead I - Lead II + Lead III”, as defined by the vector system, has a characteristic function with a zero value. However, a summation of the three leads with MR artifacts has a non-zero value, as determined by experimentation. Therefore, the synthesized signal does not have an ECG signal and includes only the components of the MR gradient artifacts. By this point, the synthesized signal is suitable for our purpose as an ANCF reference signal.

The structure of ‘Proposed Adaptive Noise Canceller’ is shown Fig.3. In the proposed method, $u(n)$ is “Lead I + Lead II + Lead III” of three channel ECG.

Also, the NLMS is used as an algorithm for update the optimum coefficients. To generate the gating pulse, exact detection of the QRS in the ECG is crucial. In our work, we used least square acceleration filter (LSAF) as a QRS

detector and respiration detector. LSAF is a simple mathematical algorithm to detect sharpness that is the most morphologically distinct.

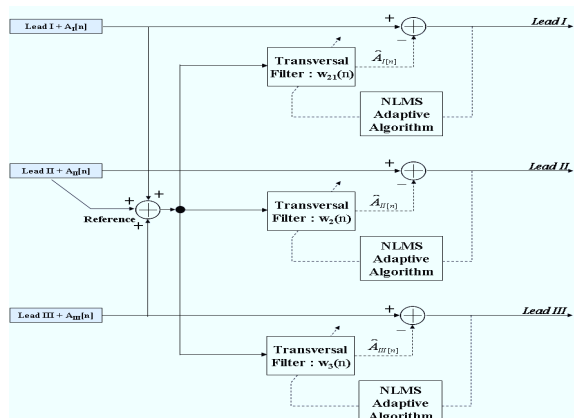

Figure 3. The Structure of Proposed Adaptive Noise Canceller

3. Experimental results and discussions

Various types of interference due to MR gradients are shown in Fig. 4

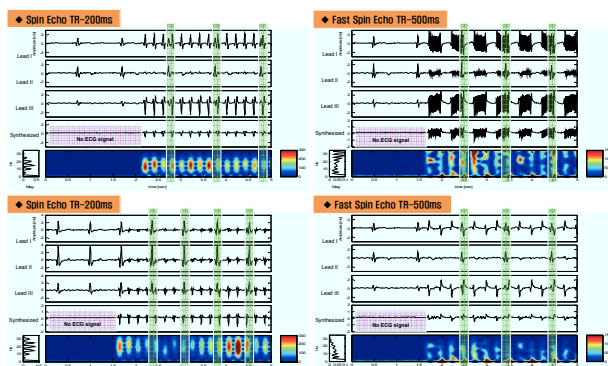

Figure 4. Various types of interference due to MR gradients

The first, second and third rows of the each panel are Lead I, Lead II and Lead III of ECG channels. The fourth rows are the synthesized signal, which was generated by combining with ECG leads, which was used as reference signal for ANCF. Also the last rows are results of time-frequency analysis for the synthesized signal.

The morphology of SE and FSE artifacts on the ECG trace are very similar with QRS of ECG signal except repetition time. Therefore these gradient artifacts could be misinterpreted as QRS complexes of ECG.

The results of minimizing MR artifacts on ECG signals and generating the cardiac MR-Gating-Pulse using the proposed ANCF are shown in Fig.5.

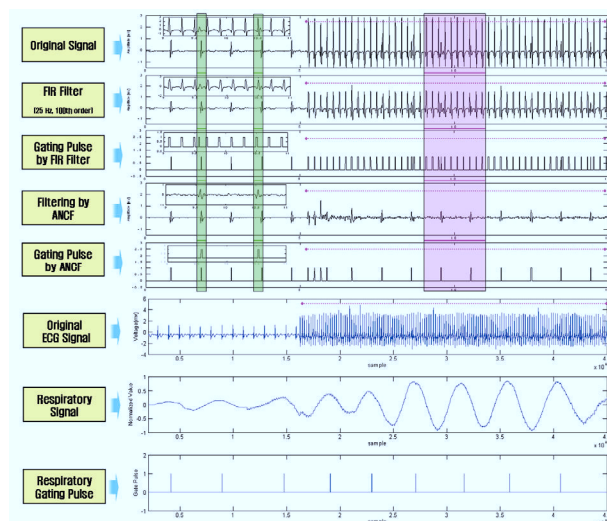

Figure 5. Filtered signal and Gating-Pulse using a conventional digital filter and the proposed ANCF method

Fig. 5 shows examples of highly distorted ECG signals. These are the results of two gradient contaminated examples (top rows of the each figure) that were obtained by using a conventional low-pass digital filter with a cut-off frequency of 25 Hz, a FIR filter of 100th order (the second rows), and the restored ECG signals (the fourth rows of each figure). In addition, the third and the last row show the ‘Gating-Pulse’ generated by a conventional filter and by the proposed method, respectively. Also, the small panels in upper left side of the figure are an enlarged version of the shadowed section. Each signal was processed under the same conditions. As shown in Fig.5, the level of artifacts was not reduced by the conventional digital filter, but the proposed filter for MRI-Gating based on the ANCF method effectively reduced the level of artifacts. Even though signals that include the MR artifact have strong power, the accurate generation of a MR-Gating-Pulse by the proposed method was possible, in contrast to the conventional digital filter.

Also it is shown that the artifact signal included to original signal was estimated exactly and the ECG signal included to original signal was estimated exactly in the fourth panel. Also, Cardiac and respiratory MR-Gating-Pulse was generated.

4. Conclusions

We have applied an ANCF, a simple and robust digital signal processing method, for gradient noise reduction and the restoration of ECG signals contaminated with MR artifacts acquired during MR sequences. The NLMS algorithm and event detector were used for updating

ANCF coefficients. In particular, the proposed ANCF does not need reference signals from an MR scanner. The reference signals of the adaptive noise canceller used in this study were a combination of the noisy, three channel ECG signals. The quality of the corrected ECG is sufficient, that a standard one-lead QRS detector can be used for correct triggering/gating of the MR machine, for any type of MR imaging application and possibility of real-time implementation.

Acknowledgements

This study was supported by a grant of the Korea Health 21 R & D Project, Ministry of Health and Welfare, Republic of Korea. (02-PJ3-PG6-EV08-0001)

References

- [1] Laudon MK, Webster JG, Frayne R, Grist TM. Minimizing Interference from Magnetic Resonance Imagers During Electrocardiography. *IEEE TRANSACTIONS ON BIOMEDICAL ENGINEERING* 1998;45.
- [2] Dimick R, Hedlung L, Herfkens R, Fram E, Utz J. optimizing electrocardiograph electrode placement for cardiac gated MRI. *Invest Radiol* 1987;22:17–22.
- [3] Wendt RE, Rockey R, Vick GW, Johnston AL. Electrocardiographic gating and monitoring in NMR imaging. *Magn Reson Imaging* 1988;6: 89–95.
- [4] Shetty AN. Suppression of RF interference in cardiac gated MRI: a simple design. *Magn. Reson Med* 1988;8:84–88.
- [5] Van Genderingen HR, Sprenger M, de Ridder JW, Van Rossum AC. carbon fiber electrodes and leads electrocardiography during MR imaging. *Radiology* 1989;171:872.
- [6] Fischer SE, Wickline SA, Lorenz CH. Novel real-time R-wave detection algorithm based on the vectorcardiogram for accurate gated magnetic resonance acquisitions. *Magn Reson Med* 1999;42:361–370.
- [7] Larson G, White RD, Laub G, McVeigh ER, Li D, Simonetti OP. Self-gated cardiac. *Cine MRI Magn Reson Med* 2004;51:93–102.
- [8] Felblinger J, Slotboom J, Kreis R, Jung B, Boesch C. Restoration of Electrophysiological Signals Distorted by Inductive Effects of Magnetic Field Gradients During MR Sequences. *Magnetic Resonance in Medicine* 1999;41:715–721.
- [9] Abächerli CR, Pasquier F, Odille M, Kraemer JJ, Schmid J. Suppression of MR gradient artifacts on electrophysiological signals based on an adaptive real-time filter with LMS coefficient updates. *MAGMA* 2005;18: 41–50.

Address for correspondence

Name: Prof. KJ Lee

Full postal address: 234, Maeji, Heungup, Wonju, Gangwon, 220-710, Korea

E-mail address: lkj5809@yonsei.ac.kr