

deFOG – a Real Time System for detection and unfreezing of Gait of Parkinson’s Patients

E. Jovanov¹, E. Wang², L. Verhagen², M. Fredrickson¹, R. Fratangelo¹

¹University of Alabama in Huntsville, Huntsville, Alabama, U.S.A.

²Rush University Medical Center, Chicago, IL, U.S.A.

Abstract— Freezing of gait (FOG) is a common complication in movement disorders, typically associated with the advanced stages of Parkinson’s disease. Auditory cues might be used to facilitate unfreezing of gait and prevent fall related injuries. We present a wearable, unobtrusive system for real-time gait monitoring, which consists of an inertial wearable sensor and wireless headset for the delivery of acoustic cues. The system recognizes FOG episodes with minimum latency and delivers acoustic cues to unfreeze the gait. We present design of a system for the detection and unfreezing of gait (deFOG), and preliminary results of the feasibility study. In a limited test run of 4 test cases the system was able to detect freezing of gait with average latency of 332 ms, and maximum latency of 580 ms.

Keywords— Wearable monitoring, Parkinson’s disease, Freezing of Gait, movement disorders, real-time processing.

I. INTRODUCTION

Movement disorders, such as shuffling, festination and akinetic episodes, are common complication of Parkinson’s disease (PD). More than 80% of PD patients suffer from movement disorders, which affect quality of lives of patients and caregivers [7]. The incidence of PD is reported as 1% of the population over the age of 50 and 10% over the age of 65. Akinesia usually denotes the sudden inability to initiate movement, which can lead to falls and injuries. It can occur as start-hesitation or during walking, and could be initiated by visual patterns on the path or by approaching narrow spaces, such as thresholds and doorways. This project has been developed to provide unobtrusive help to Parkinson’s patients in detecting and breaking the freeze of gait (FOG)¹.

There are several devices on the market that specifically target the ability to break the FOG [1]. One group of devices uses a visual stimulus for breaking the freeze. To provide the visual stimulus a laser device is attached to a cane or an assistive walker that has the ability to project a line in front of the user. This visual cue enables the freeze state to be broken [3]. While effective in breaking the freeze, these devices require the user to manually trigger the laser. The necessity for user interaction adds extra latency

between the start of the freeze and triggering of the stimulus.

Another group of devices use both visual and audio stimuli [6], [9]. Virtual reality style goggles provide a tiled-floor pattern layer to the users view. In addition an audible ‘click’ sound is generated upon each step and played through small ear buds. This is accomplished by a wearable device that monitors the movement and learns the users walking pattern [1]. The combination of the goggles and sound enable to user to feel that they are walking on a sturdy floor. There is another version of this product that provides only the audio ‘clicking’ upon each step.

Existing research projects mostly use spectral analysis of signals from three axis accelerometers placed on various parts of the lower body to record movement patterns at varying sampling rates. Han et al. from Seoul National University [4] used an FFT analysis of previously recorded accelerometer data from the legs, with corresponding video, to determine characteristics of different types of gaits. They concluded that normal gait frequency was close to 2Hz while the frequencies of a freeze gait ranged between 6-8Hz. The same group recommended the ankles as the ideal location for sensor placement due to best signal output [5]. Morrea et al. performed power analysis of accelerometer signals [8]. They also used tri-axial accelerometers attached to the ankle specifically to measure the movement of the shanks. After monitoring 11 subjects they determined 2 distinct gait bands in the frequency spectra of accelerometer signals. The ‘locomotor’ (or normal movement) band includes the frequency components between 0.5 and 3 Hz. A freeze band has a higher frequency component ranging from 3 to 8 Hz. Comparing these two bands allows for a freeze index (FI) to be calculated for a specific time. Using a window of 6 seconds they used the square of the freeze band area and divided it with the square of the area under the power spectra of the locomotor band. This calculation of the FI compensates for high frequency harmonics caused by normal walking that could potentially be perceived as a freeze condition. During normal movement the freeze index FI will be relatively stable, while the gait freeze will cause it to increase. A FI threshold can be determined to signify the beginning of a FOG. This method has shown to be up to 78% accurate in detecting FOG before being customized to the individual users. However, existing gait analysis algorithms (e.g. [4], [5]) did not provide the ability to detect freezing gait in real-time using spectral methods.

¹ This work was supported in part by ECE Research Grant 234331, University of Alabama in Huntsville.

Existing systems are obtrusive and require the user's intervention. We propose an automatic real-time system that detects gait freezing episodes in real-time and delivers acoustic stimulation to the user only at the moment of the frozen gait. In this paper we present an overall system concept and prototype implementation and results of a small feasibility study.

II. METHODS

We developed a prototype real-time monitoring system for the evaluation of algorithms for freezing gait detection and modalities for user stimulation. Our goal is to design an unobtrusive system with minimum size and maximum battery life for the maximum convenience of users.

The system consists of an inertial sensor and a wireless headset, as represented in Fig. 1. Inertial sensor was designed to provide maximum flexibility and sufficient processing power for real-time analysis of sophisticated algorithms. Block diagram of the sensor has been presented in Fig. 2 and photo of the prototype is in Fig. 3. The inertial sensor can be worn on several locations on the body, such as pager like attachment to the belt, knee, ankle, or a shoe.

The board features an ARM7 processor (NXP LPC2368) with 58kB of RAM and 512kB of flash which can be used as program memory. It can operate at up to 72MHz at 62 mA of power consumption (with no peripherals enabled) or approximately 90 mA when all peripherals are enabled. There are also three main power modes: idle, sleep, and power-down. In idle mode, execution of instructions is suspended but on chip peripherals continues to operate. This reduces the dynamic power consumption caused by processor operation down to 150 μ A. A fixed 60 μ s wakeup time is necessary for code executing in RAM. If flash access is necessary by code executing from RAM, or if code is executed out of flash, an additional 100 μ s is needed during wake up.

The on-board accelerometer is the Bosch SMB380 with configurable acceleration ranges $\pm 2g$, $\pm 4g$, and $\pm 8g$. The tradeoff is that a 10 bit ADC is used internally within the part, regardless of the selected range, so low end resolution is sacrificed in order to catch higher order acceleration events on each axis. In our experiments, signals were very often exceeding 5g during freezing gait events. The accelerometer uses approximately 200 μ A in normal mode and 1 μ A in stand by mode. It also supports a relatively fast wake up time of 1.5 ms, in order to reduce the penalty for using the power saving mode.

The Bluetooth interface is integrated module WT32 by Bluegiga that allows integration with embedded systems through serial interface. The WT32 Bluetooth module supports the following Bluetooth profiles: A2DP, AVRCP,

HFP, HFP-AG, SPP, OPP, and HID.

The A2DP profile is used to send high quality audio to Bluetooth headphones and sound equipment. The HFP-AG profile is used to send audio data to Bluetooth earpieces for cellular phones. Both profiles have applicability for our project, since our objective is to be able to send auditory stimuli to a user of the device, and either an earpiece or full set of Bluetooth headphones.

The SPP profile is also useful for wireless UART based communication with the board, and is also useful for real time wireless transport of collected data samples to a PC for recording and offline analysis and debugging.

The module contains an I2S interface for transport of digital audio samples to and from the Bluetooth wireless interface. This interface is also connected to the ARM7 processor, and is used to play the audio stimulus when freeze detection occurs. The Bluetooth module is used to delivery auditory cues to the wireless headset and to stream signals from sensors in real time during algorithm development.

The processor reads input signals from accelerometer and gyroscope with the sampling frequency of 200 Hz. All five signals (3 axis of the accelerometer and 2 rotational signals from the gyroscope) are filtered to eliminate the DC baseline, and processed in time and frequency domain.

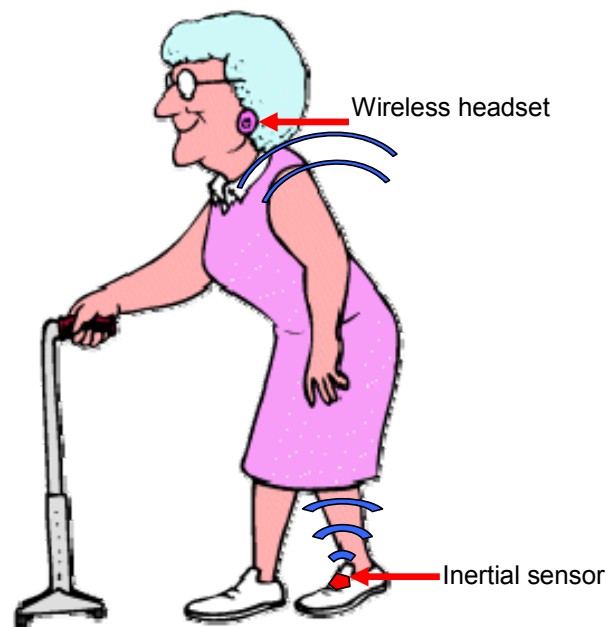

Fig. 1. Block diagram of the deFOG monitoring system.

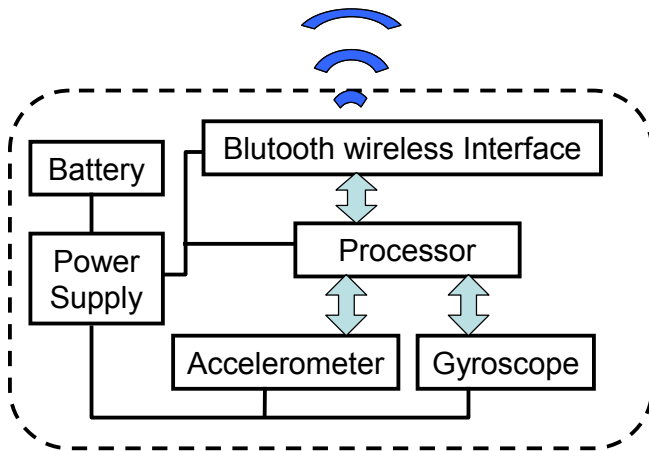

Fig. 2. Block diagram of the FOG sensor module.

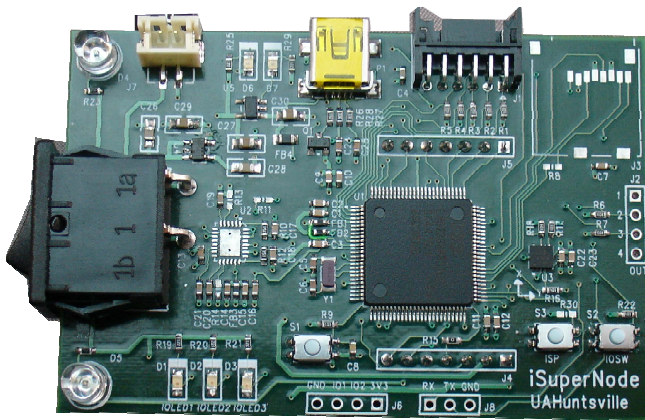

Fig. 3. Prototype FOG sensor module.

Choice of the spectral processing and the size of window determine the performance of the algorithm, frequency resolution, and latency of the processing algorithm. Since our system has to deliver a stimulus to the user in real-time, we have to use the minimum size window that allows reliable detection. Our initial processing was performed using a 128 sample window. However, this window introduces a latency of 320 ms. Consequently, we optimized our algorithm for a shorter window and currently use a 64 sample window that introduces latency of 160 ms, which is much more acceptable for effective real-time implementation. Spectral analysis was performed every 10 samples, which determines time resolution of our algorithm to 50 ms. We calculate FOG index every 50 ms and generate a warning whenever a possible FOG event has been generated.

The primary technique used for detection of the freezing gait calculates the ratio of two spectral bands [8]. The ratio of the energy in bands provides good indication of the freezing gait. Statistical analysis of the ratio provides a threshold that is relatively independent of inter-user variability. We improved the algorithm by providing a

correlation with the total power in the window. This approach effectively eliminates false detection during quiet periods.

We recorded signals from 5 experiments, 4 from simulated freezing gait events and one from the real patient and analyzed feasibility of the real-time detection. In all experiments, subjects demonstrated transition from normal walking to a freezing gait. Subjects were asked to start from a sitting position, walk along predefined path and return to the sitting position. In this paper we present results based on data received from a sensor placed on the right knee of subjects.

All signals were manually annotated from video recordings.

III. RESULTS

Preliminary analysis of accelerometer signals and the improved signal processing algorithm proved very promising for real-time detection and intervention. Although the original signal processing algorithm from which this work is derived uses a very long window (six seconds), we were able to receive very promising results with a much shorter window (320 ms), although we still have to conduct a larger clinical study to demonstrate the sensitivity and specificity of the developed algorithm.

We adjusted preliminary detection thresholds to avoid false FOG detections. In the preliminary experiments we didn't have false detections. Typical examples of recorded signals and calculated FOG index are presented in Fig. 4. The upper plot represents 3 axis of the accelerometer (X, Y, and Z), while the lower plot represents the calculated FOG index. Please note that lower plot represents moment when FOG index exceeded threshold; however, this value is calculated half a window later, when all data samples become available for spectral analysis. Therefore, in this example, FOG index exceeded thresholds at $t = 3.56$ s; however, this event was detected at $t = 3.72$ sec with 420 ms latency from the freezing event annotated from the video recording.

Average detection latency for five experiments was 332 ms, and maximum latency was 580 ms. As expected, average latency was subject dependent.

Average power consumption of the sensor with processor in active mode is 120 mA. With IDLE mode enabled, the sensor consumes 90 mA that allows at least 11 hours of battery life.

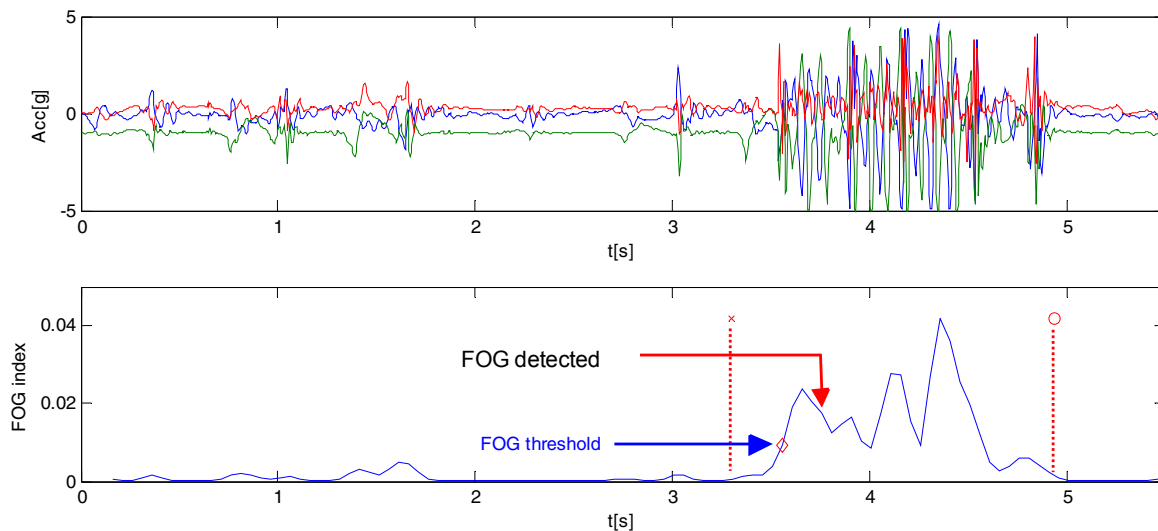

Fig. 4. Detection of freezing gait with sensor on knee; a) raw accelerometer signals; b) freezing gait index (FOG); dotted lines denote manually annotated freezing gain event.

IV. CONCLUSIONS

We present a novel approach to detection and unfreezing of gait of Parkinson's patients. Initial estimation proves the feasibility of the proposed concept for real-time unfreezing of gait.

Future work will include clinical experiments on the larger set of patients at Rush University. Longer periods of monitoring and observations of a larger number of patients will provide the ability to more effectively analyze freeze of gait and the effects of our proposed solution.

In addition to the further refinement of the algorithm, we plan to experiment with different time-frequency analysis approaches to reduce delay caused by FFT-based block processing of sampled data. Possibilities include time domain band pass digital filters for band separation, or wavelet based spectral estimation.

REFERENCES

[1] Y. Baram, S. Badarny and J. Aharon-Peretz, "Virtual Reality Feedback Cues for Improvement of Gait in Patients with Parkinson's Disease," *Proc. 10th International Congress of Parkinson's Disease and Movement Disorders*, Kyoto, Japan, October 2006.

[2] R. Constantinescu, C. Leonard, C. Deeley and R. Kurlan, "Assistive devices for gait in Parkinson's disease," *Parkinsonism and Related Disorders*, vol. 13, 2007, pp. 133-138, 2007.

[3] In-Step Mobility Products Corp., "Advanced Walking Aids Designed Specifically for Neurological Conditions," In-Step Mobility Products Corp., <http://www.ustep.com> (April 2009).

[4] J.H. Han, W.J. Lee, T.B. Ahn, B.S. Jeon and K.S. Park, "Gait analysis for freezing detection in patients with movement disorder Using three dimensional acceleration system," *Proc. of the 25th EMBS Conference*, Cancun, Mexico, Sept. 2003, vol. 2, pp. 17-21.

[5] J. Han, H.S. Jeon, B.S. Jeon and K.S. Park, "Gait detection from three dimensional acceleration signals of ankles for the patients with Parkinson's disease," *IEEE The International Special Topic Conference on Information technology in Biomedicine*, Oct. 26-28, 2006, Epirus, Greece.

[6] M.K.Y. Mak, C.W.Y. Hui-Chan, "Audiovisual cues can enhance sit-to-stand in patients with Parkinson's disease," *Movement Disorders*, 19(9): 1012-1029, 2004.

[7] O. Moore, C. Peretz, N. Giladi, "Freezing of gait affects quality of life of peoples with Parkinson's disease beyond its relationships with mobility and gait," *Movement Disorders* 2008;22:2192-95.

[8] S. Moorea, H. MacDougall, W. Ondoc, "Ambulatory monitoring of freezing of gait in Parkinson's disease," *Journal of Neuroscience Methods*, Vol. 167, Issue 2, 30 January 2008, pp. 340-348.

[9] A.M. Willems, A. Nieuwboer, F. Chavret, K. Desloovere, R. Dom, L. Rochester, D. Jones, G. Kwakkel, E. Van Wegen, "The use of rhythmic auditory cues to influence gait in patients with Parkinson's disease, the differential effect for freezers and non-freezers, an explorative study," *Disability and Rehabilitation* 2006;28(11):721-728.