

## Modeling Cardiac Pacemaker Malfunctions with the Virtual Heart Model

Zhihao Jiang and Rahul Mangharam  
Department of Electrical and System Engineering  
University of Pennsylvania  
{zhihaoj, rahulm}@seas.upenn.edu

**Abstract**—Implantable cardiac devices such as artificial pacemakers deliver therapies according to the timing information from the heart. Such devices work under the assumptions of perfect sensing, which are: (a) the pacemaker leads remain in place, and (b) the pacing therapy in one chamber (e.g. atrium) is insulated from the other chambers (e.g. ventricles). But there are common cases which violate these assumptions and the mechanisms for imperfect sensing cannot be captured by a simple signal generator. In this paper we use the Penn Virtual Heart Model (VHM) to investigate the spatial and temporal aspects of the electrical conduction system of the heart in a closed-loop with a pacemaker model. We utilize the spatial properties of the heart to model the sensing mechanism, and use clinical cases to show the validity of our sensing model. Such closed-loop evaluation of the pacemaker operation allows for functional testing of pacemaker software, the development of new algorithms for rhythm therapy and also serves as a tool for incoming cardiac electrophysiology fellows.

### I. INTRODUCTION

Many artificial implantable pacemaker malfunctions are due to lead problem. While lead fracture account for a majority of recent pacemaker recalls, lead displacements occur in over 5.2% of dual-chamber pacemakers [1]. While most pacing therapy assume correct sensing and positioning of leads, there is a strong need to investigate sensing/pacing parameters, algorithms and software operation in the presence of *crosstalk between leads* and *lead dislocation*. In order to analyze these cases, we use a spatio-temporal electrophysiological virtual heart model (VHM) in closed loop operation with a pacemaker model. The VHM has been described in our recent work [2][3][4]. In this paper, we use the VHM to analyze the pacemaker function in the presence of crosstalk and dislocation of leads.

The use of the VHM allows for spatial exploration of lead placement and parametric exploration for sensing thresholds and blanking intervals. By extracting conduction parameters from a patient, electrophysiologists can use the VHM as a tool to investigate pre-procedure surgical planning. Furthermore, this can be used as an education tool to train cardiovascular fellows. Finally, device developers can use the VHM in closed-loop studies to explore new algorithms to attenuate the effects of crosstalk and lead displacement.

The paper is organized as follows: We first provide a brief overview of the VHM and pacemaker models. Following which we use them to investigate crosstalk between leads and dislocation of leads. Through short case studies we observe how inappropriate and inefficient therapy is delivered when the underlying assumptions of perfect sensing and lead placement are violated. We conclude with a discussion on how this open-source closed-loop system can be used to further the development of cardiac rhythm therapy.

### II. VIRTUAL HEART MODEL (VHM) PLATFORM

The coordinated contraction of the atria and the ventricles are governed by the electrical conduction system of the heart (Fig. 1(a)). Despite the varieties of the cells, cells in the heart generate *action potential* when an electrical potential is applied to them (Fig. 2(a)), and their action potentials share similar properties. The action potential can be divided into: *Rest* period during which a new and normal action potential can be initialized, either by potential difference applied to the cell or by itself for pacemaker cells; *Effective Refractory Period* (ERP) which is initialized by the depolarization of the cell, and during which no new action potential can be initialized; *Relative Refractory Period* (RRP) during which a new but abnormal action potential can be initialized. In the VHM this behavior is captured using **node automaton** (Fig. 2(b)). The timing periods described above are modeled as states with corresponding timers.

The electrical potential difference caused by the depolarization of one cell can trigger depolarization of the cells nearby. This propagation property is captured using **path automaton** (Fig. 2(c)). So the electrical conduction system of the heart can be represented as conduction pathways. Since the refractory properties along a conduction pathway are governed by the tissue at both ends of the path [5], one conduction pathway can be represented as two node automata connected by a path automata. The electrical conduction system of the heart represented using node and path automata is shown in Fig. 1(b). The timing properties of the system are modeled by the timed automata and the spatial properties of the system is kept by overlaying the automata onto a 2-D heart anatomy. The VHM is implemented in Simulink. We were able to use VHM to simulate different heart conditions in a closed-loop with the pacemaker model. Some representative heart conditions including (1) Wenckebach AV nodal response, (2) AV Nodal Reentry

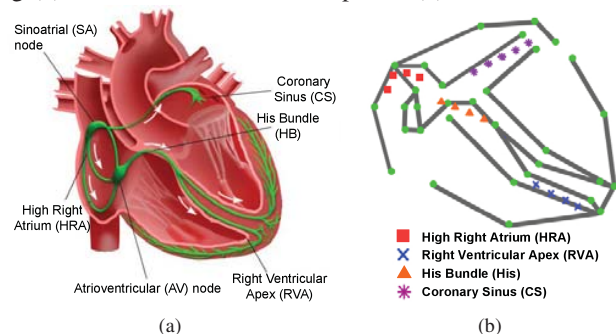

Figure 1. (a) The basic electrical conduction system of the heart. (b) Corresponding setup of nodes (dots), paths (lines) and probes (shapes) in our heart model.

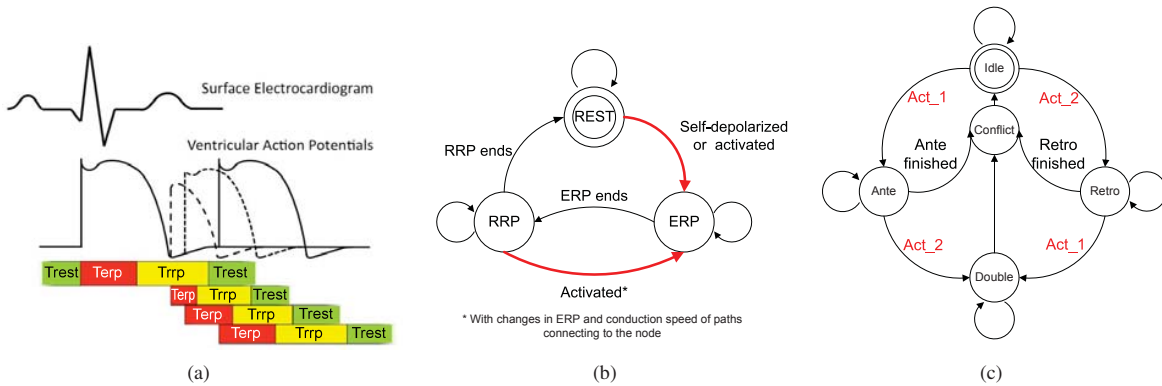

Figure 2. (a) Action potential recorded from ventricular tissue. The dashed lines show how action potential morphology changes when a stimulus is applied early to the tissue and how the corresponding timer values change. (b) Node automaton. (c) Path automaton

Tachycardia (AVNRT), (3) Atrial Flutter (AF), (4) Pacemaker mode-switch operation and (5) Pacemaker mediated tachycardia.

The VHM's functional output has been validated by the director of cardiac electrophysiology in the Philadelphia VA Hospital and by electrophysiologists in the Hospital of the University of Pennsylvania. The model generates outputs (Electrograms) which matches the output of a real heart with same underlying heart condition when inputs (Programmed pacing) are applied to it. More detailed description of node and path automaton implementation and case studies can be found in our previous papers [2][3][4].

### III. PACEMAKER MODEL

In order to show the capability of VHM in Implantable Cardiac Device Validation & Verification, a simple pacemaker model is developed. Pacemakers operate in different modes and these are labeled using a three character system (e.g. xyz). The first position describes the pacing locations, the second location describes the sensing locations, and the third position describes how the pacemaker software responds to sensing. For example, the DDD mode paces both the atrium and ventricle (D), senses both (D), and sensing can both activate or inhibit further pacing (D). We developed a basic DDD pacemaker model according to the specification derived from [6].

**1. Lower Rate Interval (LRI):** The LRI interval starts at a ventricular sensed or paced event. The LRI interval is the longest interval between two ventricular events.

**2. Upper Rate Interval (URI):** The URI interval defines the shortest interval between a ventricular event and a paced ventricular event

**3. Atrial-Ventricular Interval (AVI):** Ventricular pacing shall occur in the absence of a sensed ventricular event within the programmed AV delay when the time elapsed after the last ventricular event is between the programmed LRI and URI.

**4. Ventricular Refractory Period (VRP):** The VRP is the time interval following a ventricular event during which no ventricular sense (VS) can happen.

**5. Post Ventricular Atrial Refractory Period (PVARP):** The PVARP is the time interval following a ventricular event during which no atrial sense (AS) can happen.

According to the five primary specifications of the basic DDD pacemaker, a Simulink model was designed using temporal logic. Each component corresponds to a particular specification and communicates with others using channels. A timing diagram is shown in Fig. 3. This model can be easily translated into

formal verification tool called UPPAAL for timing verification. More information about the implementation can be found in [2].

### IV. SENSING MODEL

The electrical activity of the heart can be monitored internally using Electrograms (EGMs) and externally using Electrocardiogram (ECG). The EGMs reflect local electrical activities of the heart tissue while ECG provides a global view of the electrical activities of the heart. The morphology and timing properties of these signals are used by both physicians and Implantable Cardiac Devices to diagnose anomalies in the heart. VHM is a spatial and temporal model of the heart's electrical conduction system thus is capable of generating both signals. The signals for different heart scenarios can be used for device validation & verification.

#### A. Local electrical activity and Electrogram (EGM)

The EGMs are sensed by electrodes on the pacemaker leads which are anchored in the inner wall of the heart, which monitor the local electrical activities of the heart tissue. Timing differences between impulses and impulse shape can be used by Implantable Cardiac Devices to diagnose anomaly and deliver therapy. According to [7], a potential difference is generated when the activation wavefront passes by the electrode. In our sensing model, we use *probes* to represent electrodes. (Fig. 1(b)) The locations of the activation wavefronts are calculated from the locations of the path automata and their current timer values. The amplitude of EGM decreases when the activation wavefront moves away from the probe. We assume the decrease factor is a Gaussian function related to the distance between the activation wavefront and the probe. The potential difference caused by an activation wavefront to a probe is the signal strength of the path multiplied by the decrease factor. The amplitude of EGM from a

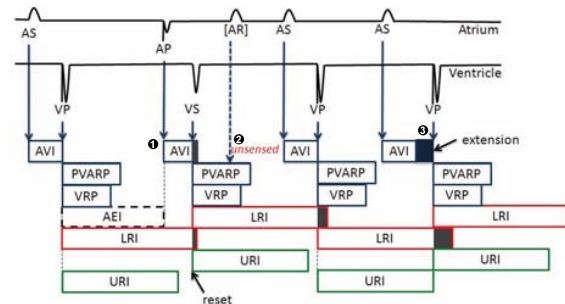

Figure 3. Simulink design of path automata

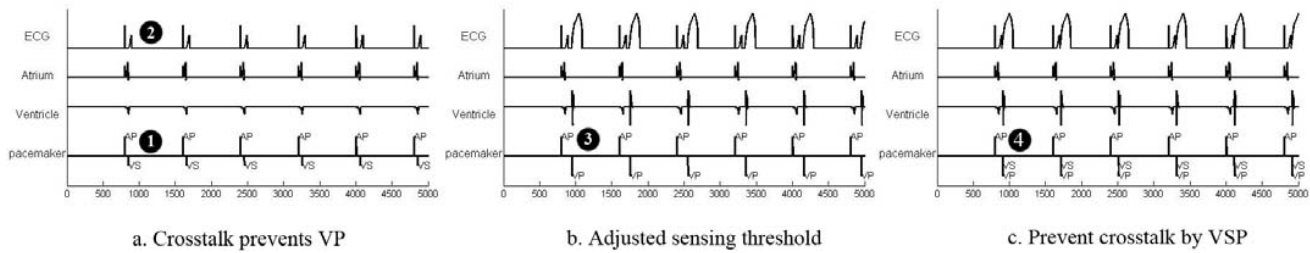

Figure 4. Crosstalk between pacemaker leads with high sensitivity in the ventricle, adjusted sensitivity and ventricular safety pacing

probe is the sum of potential differences caused by all activation wavefronts. The bipolar EGM is the subtraction between two unipolar EGMs. Fig. 5 shows that this probe model captures timing properties of EGM and the functional shape of the EGM impulses. The probes can be placed anywhere within the heart model and generate clinically-relevant EGMs.

### B. Global electrical activity and Electrocardiogram (ECG)

The ECGs are sensed by electrodes placed on the surface (i.e. skin) of the torso. ECGs are measured along different axis to provide a global view of the electrical activities of the heart. The shape, polarity and timing of the signal can be used by physicians to evaluate heart functions. VHM is a spatial and temporal model of the electrical conduction system of the heart so it's feasible to simulate clinically-relevant ECG signals. Since the current VHM is 2-D and as a preliminary effort, we only simulate the basic timing of the P wave and the QRS wave. From [8] we know that the amplitude of ECG corresponds to the projection of the heart vector onto the heart axis aligned to the lead position. In our sensing model, the amplitude of the ECG is calculated using the distance between the position of the activation wavefront to the heart axis. The fidelity of the signal can be improved by extending the VHM to a 3-D model.

## V. OVERSENSING AND CROSSTALK

Oversensing is a general term for inappropriate sensing caused by noise or far-field signals. It's very common among pacemaker malfunctions and it may result in failure to pace, competitive pacing and inappropriate therapy. Crosstalk is a special case for oversensing which occurs when the pacemaker stimulus in one chamber is sensed in the other chamber. It happens when two leads are close to each other or pacing signal in the other chamber is too strong. It is common that the ventricular lead is placed in the right ventricle outflow tract, which is close to the atrium. Fig. 4(a) shows simulated EGMs from a patient with bradycardia and complete heart block. During atrial pacing (AP), the pacing signal is sensed by the

ventricular lead 53 ms after the AP. (Marker 1) It is treated as ventricular sense (VS) signal and thus inhibit the subsequent ventricular pacing (VP). This is indicated by no QRS-wave in the ECG channel. (Marker 2) For a patient with complete heart block this will cause dangerous ventricular asystole.

Increasing the sensing threshold of the ventricular channel can prevent false sensing. In Fig. 4(b), the small signals in ventricular EGM are ignored and ventricular pacing are successfully delivered.

In the pacemaker design, Ventricular Safety Pacing (VSP) is used to prevent the consequence of crosstalk. If a ventricular event is sensed within a window shortly after an atrial pacing (AP), the pacemaker will deliver ventricular pacing (VP) a short interval (e.g. 110 ms) after the atrial pacing (AP). This function can ensure the delivery of ventricular pacing while preventing the pacing-on-T-wave behavior, which may result in ventricular fibrillation. Fig. 4(c) shows the same heart condition with pacemaker with VSP. The false ventricular event falls into the VSP sensing window, which is [30, 80] ms after the AP, and VP is delivered 110 ms after the AP. Algorithms treating crosstalk can be evaluated in this closed-loop VHM-Pacemaker system.

## VI. LEAD DISLUDGE

Lead displacement affects many patients and can result in inappropriate or ineffective therapy. Fig. 6(b) shows the simulation result for the pacemaker function when the leads are in their designated location. From the figure we can observe: 1) Each P-wave is initialized by an Atrial Pace signal. 2) Each QRS complex is initiated by a ventricular pacing signal. 3) The interval between AP and VP is 150 ms, which matches the programmed AVI period.

One common case for lead dislodge is shown in Fig. 7, where the atrial lead has fallen into the right ventricle outflow tract. In this case the atrial lead senses from the ventricle rather than atrium and atrial pacing will initiate a ventricular event. Fig. 6(c) shows the simulated EGMs in this case. The figure reveals several facts: 1) No P wave is sensed or tracked (Marker 1). 2) Atrial Pace initiates an abnormal, wide QRS which is then sensed by the ventricle lead (Marker 2). 3) Intermittent appearance of VP on QRS 110 ms after the AP. The ventricular lead can receive signal from: 1) pacing signal sent from the atrial lead, 2) the intrinsic A-V conduction path. The two path are shown in Fig. 7 and form a timing race condition. When the signal from the atrial lead arrives the ventricular lead first, it will trigger VS. If the intrinsic signal arrives the ventricular lead during the VSP sensing window (defined in previous section), it will trigger VSP. Although the pacing is 'safe' because the pacing is early enough to avoid the vulnerable refractory period,

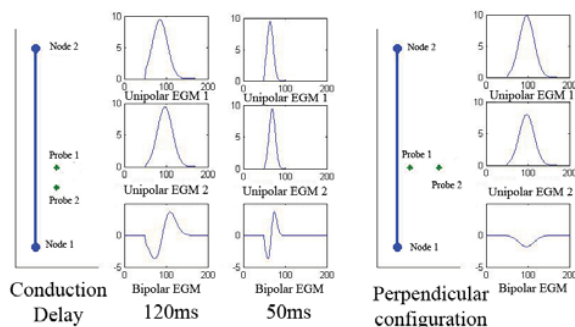

Figure 5. The left columns show the placement of probes in relation to the path; the right columns show the functional EGM



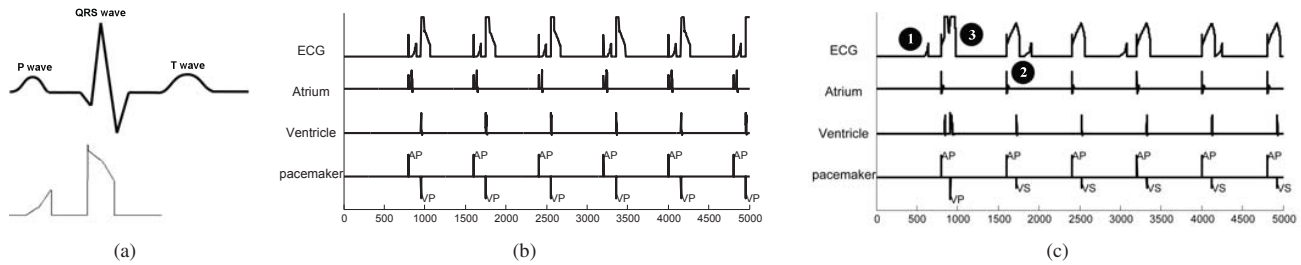

Figure 6. (a) Top: Lead II ECG signal, Bottom: VHM simulated ECG signal (b) Pacemaker function before lead dislodge. (c) Pacemaker function after lead dislodge

the damage caused by pacing on depolarized tissue is currently a matter of much investigation.

The above two cases of crosstalk and lead dislodgement are examples of spatio-temporal analysis of the pacemaker function under non-ideal sensing by the device leads. Such closed-loop investigation will further the development of approaches to detect and prevent under and over pacing that damage the heart tissue.

## VII. RELATED WORK

Modeling of cardiac arrhythmias in both electrical timing and electro-mechanical approaches has been an important topic of research over the past two decades. [9] and [10] have used a three-dimensional discrete element mesh to model supraventricular tachycardias, while [11] and [12] modeled the activity of individual ion channels to simulate arrhythmias. These models were created for research or diagnostic purposes and do not have the capability to have *closed-loop interaction with medical devices*. Medtronic's Virtual Interactive Patient simulator can be used in closed-loop operation with real medical devices, but the sophistication of this signal generator allows it to be used as a training tool only and not during the testing of device software itself [13]. [14] also extracted the timing properties of the cardiac conduction system to model the heart. Their model was able to do close-loop simulation with pacemaker software for several clinically-relevant cases and produce template-based ECG signals. The VHM platform builds upon this modeling technique but also allows for cardiac device software verification and interaction with real devices [2][3][4].

## VIII. CONCLUSION

As the software-based algorithms used in implantable medical devices become more complex, the design of bug-free medical device software is becoming an increasingly difficult problem. Safety recalls of pacemakers and implantable cardioverter defibrillators between 1990 and 2000 affected over 600,000 devices. Of these, 200,000 or 41%, were due to firmware issues and their

effect continues to increase in frequency [15]. The high-level diagnostic and therapeutic operations of artificial pacemakers requires a clinically-relevant and interactive testing methodology to fully validate their functionality. The VHM provides closed-loop interaction with both medical device hardware and software implementations. We presented two case studies on lead crosstalk and lead displacement to demonstrate how this closed-loop interaction can result in inappropriate and inefficient rhythm therapy. Such investigation allows for the development of new timing derangement detection algorithms, techniques for on-line sensitivity calibration to prevent oversensing and undersensing and allows the clinician to select more appropriate blanking intervals for the patient.

## REFERENCES

- [1] B. Fuertes and J. Toquero et. al. Pacemaker Lead Displacement: Mechanisms And Management. *Indian Pacing Electrophysiology Journal*, 2003.
- [2] Z. Jiang, M. Pajic, A. T. Connolly, S. Dixit, and R. Mangharam. Real-time Heart Model for Implantable Cardiac Device Validation and Verification. *22st Euromicro Conference on Real-Time Systems, (IEEE ECRTS)*, 2010.
- [3] Z. Jiang, M. Pajic, and R. Mangharam. Model-based Closed-loop Testing of Implantable Pacemakers. In *ICCPs'11: Proceedings of the ACM/IEEE Second International Conference on Cyber-Physical Systems*, April 2011.
- [4] Z. Jiang, A. T. Connolly, and R. Mangharam. Using the Virtual Heart Model to Validate the Mode-Switch Pacemaker Operation. *32nd Annual International Conference of the IEEE Engineering in Medicine and Biology Society, (IEEE EMBC'10)*, 2010.
- [5] M.E. Josephson. *Clinical Cardiac Electrophys.* Lippincot Williams and Wilkins, 2008.
- [6] PACEMAKER System Specification. Boston Scientific. 2007.
- [7] W. G. Stevenson and K. Soejima. Recording techniques for clinical electrophysiology. *J Cardiovasc Electrophys.*, 2005.
- [8] R.N. Fogoros. *Electrophysiologic Testing*. Wiley, 1999.
- [9] D. Wei et. al. Computer Simulation of Supraventricular Tachycardia with the Wolff-Parkinson-White Syndrome using Three-dimensional Heart Models. *J. of Electrocardiology*, 23(3), 1990.
- [10] D. M. Harrild and C. S. Henriquez. A Computer Model of Normal Conduction in the Human Atria. *Circ Res*, 87(7), 2000.
- [11] N. Virag, J. Vesin, and L. Kappenberger. A Computer Model of Cardiac Electrical Activity for the Simulation of Arrhythmias. *PACE*, 21(11), 2006.
- [12] J. Beaumont et. al. A Model Study of Changes in Excitability of Ventricular Muscle Cells. *Am J Physiol Heart Circ Phys.*, 1995.
- [13] *Medtronic ViP-II Virtual Interactive Patient: User's Manual Software v1.5*. Rivertek Medical Systems, 2006.
- [14] M. Malik, T. Cochrane, D. W. Davies, and A. J. Camm. Clinically Relevant Computer Model of Cardiac Rhythm and Pacemaker/Heart Interaction. *Medical & Biological Eng. & Comp.*, 1987.
- [15] W. H. Maisel et. al. Recalls and safety alerts involving pacemakers and implantable cardioverter-defibrillator generators. *JAMA*, 286(7), 2001.

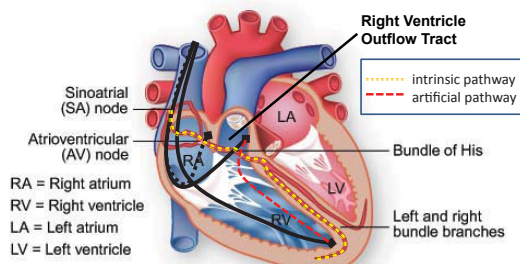

Figure 7. Dotted line shows the location where the atrial lead should be