

A wireless multichannel EEG recording platform

S. Filipe, G. Charvet, M. Foerster, J. Porcherot, J.F. Bêche, S. Bonnet, P. Audebert, G. Régis,
B. Zongo, S. Robinet, C. Condemine, C. Mestais, R. Guillemaud

Abstract— A wireless multichannel data acquisition system is being designed for ElectroEncephaloGraphy (EEG) recording. The system is based on a custom integrated circuit (ASIC) for signal conditioning, amplification and digitization and also on commercial components for RF transmission. It supports the RF transmission of a 32-channel EEG recording sampled at 1 kHz with a 12-bit resolution. The RF communication uses the MICS band (Medical Implant Communication Service) at 402-405 Mhz. This integration is a first step towards a lightweight EEG cap for Brain Computer Interface (BCI) studies. Here, we present the platform architecture and its submodules. *In vivo* validations are presented with noise characterization and wireless data transfer measurements.

I. INTRODUCTION

A Brain Computer Interface (BCI) is a system for translating the brain neural activity into commands for external devices [1, 2]. It is built on intentionally modulated brain activity recorded directly from the brain. The signal processing must be performed online and the user must obtain a feedback, with short latency, about the success or failure of his intended action. Indeed feedback is well-known “to support reinforcement during the learning/training process or in controlling the application”[10]. Thus a BCI system is a closed-loop system where ideally both the user

and the machine adapt to each other. It usually aims at restoring communication [3] and control in severely motor-disabled subjects [4] that cannot use conventional communication channels like muscles or speech to interact with their environment.

To measure brain neural activity, different measurement systems have been proposed ranging from invasive recording techniques (micro-electrodes implanted into the cortex to record single-unit or multi-unit activity, ECoG) to non-invasive ones. The latter ones can be divided into magnetic fields (MEG), electrical potentials (EEG) or hemodynamic (NIRS) measurements. ElectroEncephaloGraphy (EEG) is an old technique since the first recordings done by H. Berger in 1924. It is the most widely used technique in the current BCI realizations as it is the easiest and less intrusive method for the user.

In the first BCI studies, the recording systems were mainly based on standard medical EEG devices. These devices are usually cumbersome with the leads from the electrodes to the electronics module. Expertise was needed to place the electrodes. Therefore there is a trend to develop easy to use EEG cap with miniaturized electronics embedded in the cap. In the current state-of-the-art in wireless EEG recording devices, the main systems are:

- Neurosky commercial EEG system (one electrode, mainly for gaming,) [5]
- Emotiv commercial EEG system (14 electrodes, for gaming and biofeedback,) [6]
- IMEC helmet with 8 electrodes [7], for research purposes

Compared to previous medical EEG devices, these systems provide comfort to the user with a small number of electrodes.

In the context of the ROBIK project, which overall goal is to design a BCI virtual keyboard, a new EEG cap is being designed with a miniaturized and low power wireless electronics (WIBEEM electronic board) altogether with a large number of electrodes (32 electrodes) to cover the whole brain. To record high quality signals, a dedicated ASIC including a very low noise amplifier has been developed. With a larger number of electrodes, it becomes possible to address with a unique EEG cap, various BCI protocols (P300, motor imagery, SSVEP), that is to say hybrid BCI, or to have a system very close to EEG medical needs.

Manuscript received April 16, 2011. This research project was financially supported by the National Research Agency (ANR) through the call for proposals TecSan.

S. Filipe is with the CEA/LETI, MINATEC Campus, Department DTBS, Grenoble, France (e-mail: sabine.filipe@cea.fr).

G. Charvet is with the CEA/LETI/CLIMATEC, MINATEC Campus, Grenoble, France (e-mail: guillaume.charvet@cea.fr).

M. Foerster is with the CEA/LETI, MINATEC Campus, Department DTBS, Grenoble, France (e-mail: michael.foerster@cea.fr).

J. Porcherot is with CEA/LETI, MINATEC Campus, Department DTBS, Grenoble, France (e-mail: jean.porcherot@cea.fr).

J.F. Bêche is with the CEA/LETI, MINATEC Campus, Department DTBS, Grenoble, France (e-mail: jfbeche@cea.fr).

S. Bonnet is with the CEA/LETI, MINATEC Campus, Department DTBS, Grenoble, France (e-mail: stephane.bonnet@cea.fr).

S. Robinet is with the CEA/LETI, MINATEC Campus, Department DSIS, Grenoble, France (e-mail: stephanie.robinet@cea.fr).

P. Audebert is with the CEA/LETI, MINATEC Campus, Department DSIS, Grenoble, France (e-mail: patrick.audebert@cea.fr).

G. Régis is with the CEA/LETI, MINATEC Campus, Department DSIS, Grenoble, France (e-mail: guillaume.regis@cea.fr).

B. Zongo was with the CEA/LETI, MINATEC Campus, Department DSIS, Grenoble, France.

C. Condemine is with the CEA/LETI, MINATEC Campus, Department DSIS, Grenoble, France (e-mail: cyril.condemine@cea.fr).

C. Mestais is with the CEA/LETI/CLIMATEC, MINATEC Campus, Grenoble, France (e-mail: corinne.mestais@cea.fr).

R. Guillemaud is with the CEA/LETI, MINATEC Campus, Department DTBS, Grenoble, France (e-mail: regis.guillemaud@cea.fr).

The paper is organized as follows: first, we present the general architecture of the miniaturized electronic WIBEEM platform. Then we present the characterization and validation of its submodules (ASIC, RF transmission). Finally the specifications of the future 32-channel WIBEEM electronics board are presented before a conclusion.

II. GENERAL ELECTRONICS ARCHITECTURE FOR MINIATURIZED EEG

Our goal is to develop a miniaturized electronics for EEG or ECoG recording with a large number of electrodes (up to 32), while using as much as possible COTS (commercial-off-the-shelf) components.

We propose to use a MSP430 ultra-low power microcontroller to provide the control of the different modules, and a Zarlink low power wireless data link module. No component was identified as commercially available for EEG signal amplification and analog to digital conversion. Therefore, a dedicated Application Specific Integrated Component (ASIC) has been developed.

A. Integrated Electronic: ASIC CINESIC

Interfacing electrodes using discrete electronics rapidly limits the number of channels, creating the need for highly integrated solutions to achieve sufficient spatial resolution [8][9]. For this purpose, a dedicated ASIC CINESIC32 (Circuit for NEuronal Signal Conversion) is being developed with the two major constraints in mind: ultra low power consumption and patient's safety.

A first 8-channel version CINESIC8 has already been developed and tested. The ASIC filters, amplifies and digitizes the EEG data acquired from the electrodes. The architecture of CINESIC8 is shown in Figure 1.

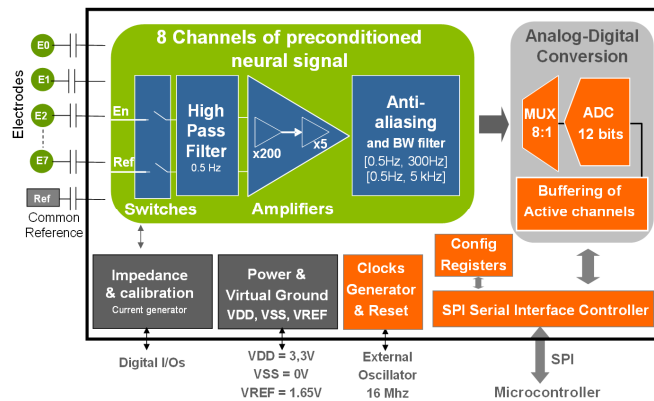

Figure 1: Architecture of the CINESIC8 ASIC

Each input channel is combined with an external capacitor (1.5nF) in order to suppress the risk of leaking current in a first default condition, which is essential for medical applications. The analog channel is comprised of a fully differential low-noise amplifier, followed by a voltage gain amplifier and a programmable low-pass filter. The consumption of one analog channel is ~34µA.

Digital peripherals such as configuration registers and a SPI (Serial Peripheral Interface) controller are also integrated on the chip. A special attention was paid on configurability to target different applications. A dedicated protocol was defined to address configuration registers. Consequently, the user can enable or disable each channel, configure the input switches in different modes, set the amplification stages in different gain (4 possible values: x1,000, x200, x5, x1) and set the frequency bandwidth (BW1= [0,5Hz; 300Hz], BW2= [0.5Hz; 3kHz]). For EEG applications, the channels will be configured to a [0.5Hz; 300Hz] bandwidth and a 60dB voltage gain. Each analog data is digitized through a 12-bit ADC (10.7 ENOB). The nominal sampling frequency is 1 kHz per channel. The CINESIC8 chip was designed in CMOS 0.35µm technology.

B. Microcontroller module

The MSP430F2618-EP from Texas Instruments was chosen for its ultra low power characteristics, its multiple communication interfaces and because it belongs to the HiRel series from TI's Enhanced Products program. The MSP430 controls both the RF link and the data acquisition from the ASIC. A 3 axis accelerometer (ADXL345 from Analog Devices) will also be connected to the microcontroller.

C. RF link module

The RF communication module ZL70101 from Zarlink was chosen for its ultra low power characteristics (typically 5mA in RX/TX), its high data rate (~ 800 kbps raw data for ~480 kbps effective data rate) and because it was designed specially for medical applications operating in the 402 - 405 MHz MICS (Medical Implantable Communications Service) band.

III. VALIDATION OF SUBMODULES

Prior to the development of the 32-channel EEG WIBEEM platform, the different functional modules were tested and validated individually on separate boards.

We present in the following tests of signal data transfer (RF link) and evaluation of signal recording.

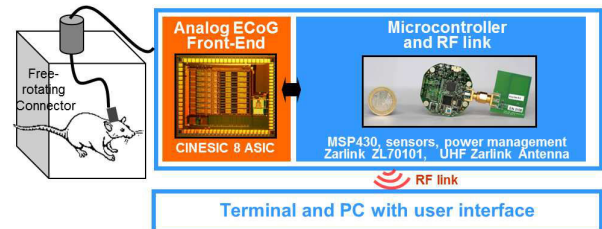

Figure 2: Experimental set-up with ECRINS board and CINESIC8

To achieve these tests, the experimental setup, see Figure 2, was made up with :

- an ASIC CINESIC8 mounted on an evaluation board, to record the signals
- a board comprising the MSP430 microcontroller, the sensors and the RF link (ECRINS board)

A. Noise characterization

As a starting point, we have evaluated the input referred noise of the recording system by setting all the input channels of the ASIC to the ground.

Figure 3 presents the power spectral density of the input-referred signal at sampling frequency 1 kHz. As expected, the measured bandwidth has a cut-off frequency at 300 Hz.

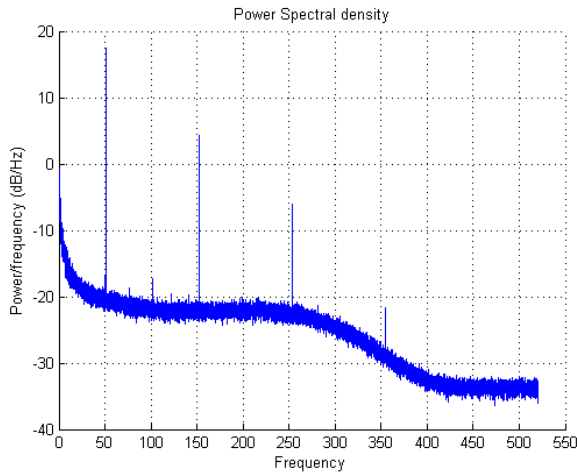

Figure 3: Power spectral density with electrodes set to ground

For this configuration, the input-referred noise RMS in BW1 [0,5Hz; 300Hz] is computed for different channels. The median noise rms value is 725 nV.

B. Data transmission evaluation

Thanks to the experimental set-up based on the ECRINS board (Figure 4), preliminary throughput tests have been performed.

These first tests confirmed the feasibility of transmitting 32 channels with a 12-bit resolution sampled at 1 kHz per channel. The effective data throughput over several hours was measured and is comprised between 400 kbps and 450 kbps, with an acceptable data loss of less than 0.5 %, which is sufficient for real time performances.



Figure 4: Picture of the ECRINS prototype board

C. In vivo signal recording with CINESIC

As regulations for validation of a mock up on a human are too complex, first in vivo tests were performed on rodents in order to validate the overall functionality of the system. The experimental procedures and animal care were carried out in

compliance with the European Community Council Directive of 24th November 1986 (86/609/EEC). Screws were fixed in the skull of the animal and used as electrodes.

The experimental setup was made up of the ASIC CINESIC8 mounted on an evaluation board combined with the ECRINS platform. The EEG signal is transmitted wirelessly to a PC through a Zarlink toolkit development receptor. The electrodes are connected by wire through a free-rotating connector to the ASIC CINESIC8 (Figure 2).

EEG activity was recorded on all electrodes implanted in the rat (example in Figure 5), and a typical spontaneous EEG activity was observed at 4-7Hz, as it can be seen in Figure 6.

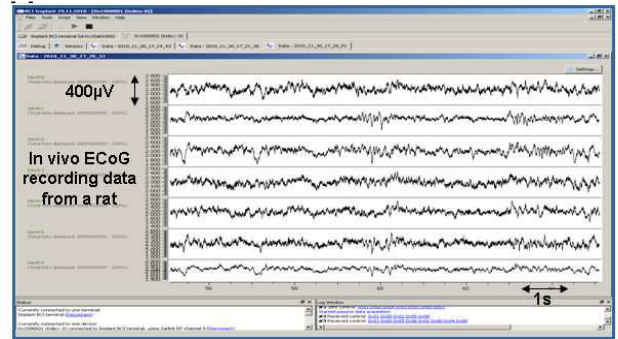

Figure 5 : Experimental in vivo EEG acquisition on rat

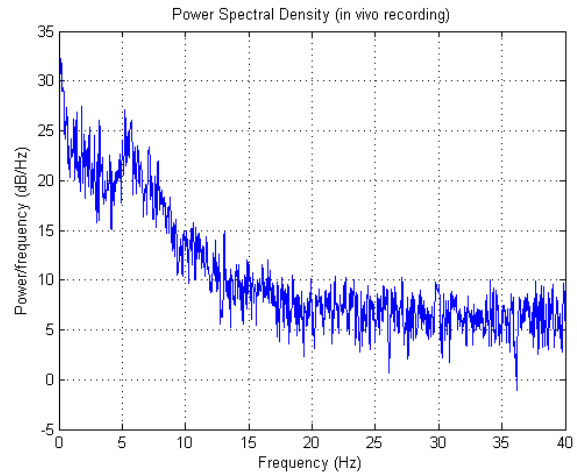

Figure 6: Power spectral density during in vivo experiments

IV. THE WIBEEM PLATFORM

The WIBEEM (Wireless BCI EEG Electronics module) platform is under development and will be a wearable device for wireless 32-channel EEG recording. The design of the WIBEEM platform takes into account all the constraints of a wearable medical device: ultra-low power, miniaturization, safety and reliability.

It will be based on the general architecture presented in section II. The electronics module consumption at full wireless data streaming conditions is around 25mA at 3.3V. Work is currently under progress to reduce this consumption

by a significant amount. To guarantee 24 hours of continuous operation on battery, the electronics operates on four AAA rechargeable batteries. These batteries are a first suitable solution: lightweight and small, they can be easily fitted on the EEG cap or headset. They can be found anywhere and the battery charger is standard. AAA batteries will be replaced in the future by higher energy density Li-Ion rechargeable batteries

The block diagram of the WIBEEM platform is shown in Figure 7. The WIBEEM prototype will be designed to fit in a EEG cap. It will be split in two square boards (typical border length 5 cm): a mother board for the MSP, RF link component and ASIC, and a second board for ON/OFF switch, status LEDs and debug connectors. Antenna can be flexible Kapton and integrated in the cap.

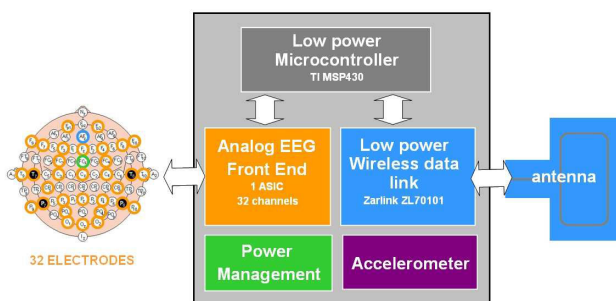

Figure 7: The WIBEEM Architecture

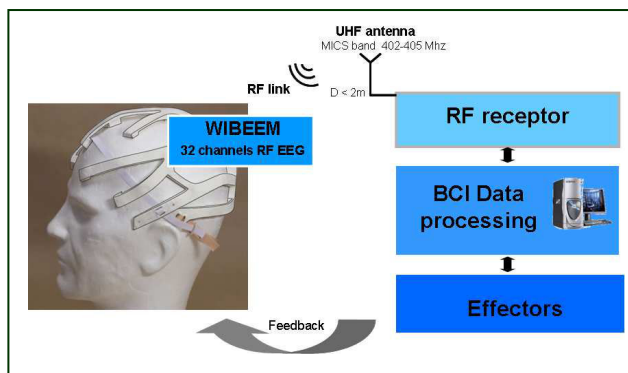

Figure 8: The experimental set-up for WIBEEM

The WIBEEM platform will offer a user-friendly interface allowing rapid and easy setting of acquisition parameters like sampling frequency of the device and the gain of each electrode depending on the measured bioelectrical activity. Furthermore, all data from the 32 channels can be saved and reloaded with the WIBEEM software or analyzed later using Spike2 software (Cambridge Electronic Design Limited, UK). The EEG board will be used in the domain of BCI in a typical overall set up presented in Figure 8.

V. CONCLUSION

An innovative platform is being developed in the context of the ANR TECSAN-funded ROBIK project, and in relationship with a BCI implant project lead by Prof. A.L. Benabid in the context of the CEA/LETI/CLINATEC®

structure. WIBEEM will be a wireless low power 32-channel data acquisition system dedicated to ElectroEncephaloGram (EEG) recordings. The different sub-modules have been tested in terms of noise performances and RF dataflow transfer. In addition, first in vivo tests of the functional blocks of the electronics architecture were successfully performed on rodents.

The development of the WIBEEM platform is a first step towards the development of a wearable multichannel EEG recording device for clinical investigations or BCI applications. An important part of the work to be done for transforming the mock up into an actual wearable device lies in optimizations in terms of safety and reliability. The electronics platform will also have to be integrated in a frame in order to obtain an easy-to-wear cap.

ACKNOWLEDGMENTS

This work was performed thanks to the close collaboration of the technical staff of CEA/LETI/DTBS, CEA/LETI/DSIS and CEA/LETI/CLINATEC® and Pr A.L. Benabid. The authors wish also to thank C. Moro and T. Costecalde (CLINATEC®) for their involvement in the *in vivo* validations and ENSCI students for EEG cap architecture proposals.

REFERENCES

- [1] Nicolelis, MA. *Brain-machine interfaces to restore motor function and probe neural circuits*. *Nat. Rev. Neurosci.* 4(5), 417-422, (2003).
- [2] Wolpaw, JR., McFarland, DJ., Neat, GW., Forneris, CA. An EEG-based brain-computer interface for cursor control. *Electroencephalogr. Clin. Neurophysiol.* 78, 252-259 (1991).
- [3] Leuthardt, EC., Miller, KJ., Schalk, G., Rao, RP., Ojemann, JG. ECoG-based brain computer interface--the Seattle experience. *IEEE Trans. Neural Syst. Rehabil. Eng.* 14, 194-198, (2006).
- [4] Hochberg, et al., Neuronal ensemble control of prosthetic devices by a human with tetraplegia, *Nature* 442, 164-174, (2006).
- [5] <http://www.neurosky.com/>
- [6] <http://www.emotiv.com/>
- [7] Brown, L.; van de Molengraft, J.; Yazicioglu, R.F.; Torfs, T.; Penders, J.; Van Hoof, C.; A low-power, wireless, 8-channel EEG monitoring headset, *Engineering in Medicine and Biology Society (EMBC), 2010 Annual International Conference of the IEEE*, vol., no., pp.4197-4200, Aug. 31 2010-Sept. 4 2010
- [8] O. Billoint, J. P. Rostaing, G. Charvet, and B. Yvert, *A 64-channel ASIC for in-vitro simultaneous recording and stimulation of neurons using microelectrode arrays*, *Conf. Proc. IEEE Eng Med. Biol. Soc.*, vol. 2007, pp. 6070-6073, 2007
- [9] G.Charvet, et al. "BioMEA™: A versatile high-density 3D microelectrode array system using integrated electronics" *Biosensors and Bioelectronics* Volume 25, Issue 8, 15 April 2010, Pages 1889-1896
- [10] J.d.R. Millán, et al. (2010). *Combining brain-computer interfaces and assistive technologies: state-of-the-art and challenges*, *Frontiers in Neuroscience*, Sept. 2010, Vol. 4, No. 161, p. 1-15.