

A wearable Ultrasound multi-transducer array system for Abdominal Organs Monitoring

Michail Tsakalakis and Nikolaos Bourbakis
ATR Center, Engineering College, Wright State University, Dayton OH, USA
(tsakalakis.2, nikolaos.bourbakis)@wright.edu

Abstract— Ultrasound imaging (USI) or Medical Sonography (MS) as it is formally called is widely used in biomedical applications over the last decades. Form the Intensive Care Unit minimally invasive monitoring to the recent point of care testing besides the patient's bed. US imaging outcomes can provide clinicians with a thorough view of the internal parts of the human body at a very low expense. In this paper, we insinuate an alternative approach compared to already existing ones of capturing US images. We propose a wearable ultrasound system composed of an array of ultrasound circular 2D transducers, integrated in a belt, for point of care monitoring of the abdominal region and particularly the liver for critical ill subjects. The configuration of the array and the type of the transducers will entail a system capable of providing clinicians with high resolution 2D imaging of the region of interest (ROI) as well as 3D representation of whole organs without theirs assistance.

I. INTRODUCTION

A wide use of ultrasounds has been observed in different fields from non-destructive testing (NDT) or non-destructive evaluation (NDE) [1][2] and Sounds Navigation And Raging (SONAR) systems [3] for object detection and measuring distances to numerous medical applications. In medicine, ultrasound is a diagnostic imaging technique that uses acoustic waves operating in the frequency range of 2-20 MHz for visualization of body structures and various internal organs. US imaging is one of the most widely used method in medical imaging among with the Computational Tomography (CT) Magnetic Resonance Imaging (MRI) and X-rays for prognosis, diagnosis and therapeutic purposes. The reasons which ultrasonography has attracted the interest of numerous researchers and clinicians during the last decades are apparent. Ultrasonography is a minimally or a non-invasive technique and the acoustic waves that it produces make no use of ionizing radiation. The overall cost is considered relative low compared to the previously mentioned modalities such as MRI and CT and it is more easily accessible for the general public. Almost every hospital, nowadays, is equipped with machines capable of providing 3D, even 4D (Real-Time 3D) tissue visualization of great quality. Such images can provide physicians with vital information about normal or abnormal functionality of a wide variety of internal organs like lung, pancreas, liver to name but few.

In the firsts decades from the time that ultrasound was proposed, most of the medical applications were limited to

gynecology and obstetrics [4][5]. Nowadays ultrasound technology is used in identifying and monitoring a wide variety of pathologies and abnormalities as well as for therapeutic purposes. In therapeutics there is an effort of adopting ultrasound for bone-healing [6], thrombolysis (sono-thrombolysis) [7], and in general to promote gene therapy to specific tissues [8]. Use in dentistry has also been reported [9]. Nevertheless, ultrasound technology is primarily used for diagnosis and monitoring purposes of the internal of the human body. Minimally invasive Intravascular Ultrasound (IVUS) is among the best techniques used so far in artery reconstruction and in the evaluation of atherosclerosis [10]. A wide number of diseases and pathologies associated with many abdominal organs such as lung [11], pancreas [12], liver [13] can be monitored and managed using ultrasound imaging techniques. Abdominal monitoring can be conducted either in hospitals with bulky and expensive machines, providing enhanced quality or with cheaper portable apparatus for point of care testing. In the present work we will focus our interest on latter systems for detection and management of liver-related pathologies.

Liver is counted as one of the most critical organs with numerous fundamental functionalities in human's metabolism. It is the largest internal organ and weights between 1.44 – 1.66 kg. More than 500 functions are related with the liver and as a consequence there is vast range of liver related diseases such as Liver cirrhosis, Liver benign and malignant growths, Hepatitis, Liver congenital defects, Fatty Liver and Alcohol induced Diseases.

The aforementioned pathologies maybe diagnosed with blood tests or biopsies in hospital laboratories or with the use of medical ultrasonography. The type and the state of the disease define each time the appropriate instrument to be used for more accurate and precise results. Evaluation of the accuracy of the ultrasound imaging for liver related diseases detection has been conducted by different clinician parties and researches [14] and the findings encourage the use of such low-cost, easily accessible non-invasive technique for most of the aforementioned disorders.

II. SYSTEMS AND METHODS

Despite the vast range of ultrasound systems, most of them are composed of three fundamental components: a) the probe in which the appropriate transducer is integrated, b) the main board which is responsible for the acquisition and

the processing of the signal c) and the display monitor (Figure 1).

The main board can be further divided into three parts: a) the front-end, b) the mid-end and c) the back-end unit. The front-end unit is responsible for the integration of the transducer to the acquisition board and for the beamforming scheme to be adopted. Its complexity is highly depends on the type of the transducer and the number of channels the architecture uses to produce the final ultrasound image. In the mid-end and the back end all the appropriate signal and image processing techniques are applied to the raw data. Scan conversion entails the final step of the procedure and transforms the acquired processed data to a 2D image readable image. [15].

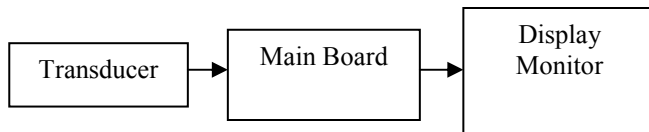

Fig. 1. Basic components of an ultrasound machine

A. Common Types of Transducers

Different classification models already exist regarding the type of transducer. Criteria for classification can be considered the configuration of the array elements that compose the whole transducer as well as the method that each type uses in the image formation or volume visualization procedure. Typical ultrasound transducers available in the market (Figure 2) are: a) linear arrays, b) sector arrays, c) curvilinear arrays, d) 2-D arrays (rectangular or annular) and e) phased array transducers (1D or two 2D). The vast majority of the above transducers are based on piezoelectric elements (mostly lead zirconate titanate, PZT) to produce the acoustic waves. Recently was proposed the use of Capacitive micro-machined Ultrasonic transducers (CMUT) instead of piezoelectric elements as the future in ultrasound imaging delivering new expectations in the field [16].

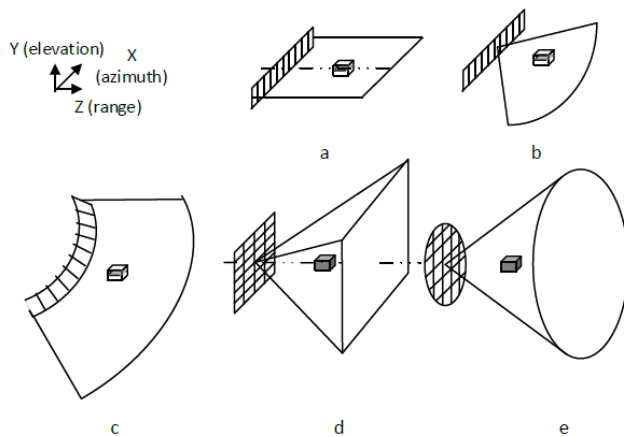

Fig.2. Different types of transducers and the region that can monitor: a) linear arrays, b) 1D phased arrays, c) curved arrays d) 2D phased arrays (square) and e) 2D phased circular arrays

B. 3D – Volumetric Transducers

Another classification model distinguishes the ultrasound scanners able to produce a 3D image representation into: a) Mechanical scanners, b) 2D Phased array scanners and c) Capacitive Micro-machined Ultrasound Transducers (CMUT).

Real-time Volumetric imaging is one of the challenges in medical ultrasound that have attracted the attention of many researchers. 3D images may hold more information in comparison with multiple 2D slices of the ROI and can be used in surgery planning. Commercial machines uses 2D phased array probes for 4D representation. The major drawback resides in the fact that the cost and the complexity of both the acquisition system and the transducer are radically increased. That is why 2D arrays consist of thousands of piezoelectric elements in comparison to the linear ones where a few hundreds are sufficient to produce a high quality B-Mode image. An exhaustive research in the capabilities and the potential of 3D ultrasound scanners can be found in [17].

C. Beamforming

The critical factor of the success of an ultrasound system is the effectiveness of the beamforming technique that is adopted. Beamforming is the process of using electronic circuits to steer and focus the overall beam of multiple sound waves at a specific focal point. Regarding the type of the transducer, the dimension of the image (2D or 3D), and the application itself a wide variety of beamforming schemes and architectures have been proposed.

The first beamforming scheme for 3D images was proposed by Smith and Von Ramm [18][19]. In 1998 G.R Lockwood et al. [20] propose the first real-time sparse synthetic aperture beamforming scheme using mechanically scanned linear phased array transducer to achieve the 3D visualization. Two of the most known techniques are the Full-Phased Array (FPA) and the Classic Synthetic Aperture (CSA). The former offers best quality in images but it requires huge amount of power and computational complexity as it makes use of all the piezoelectric elements. Thus, an array with N elements requires N channels. This is prohibitive for 2D phased arrays especially for portable application. The latter with the use of multiplexing unit activate only one element at a time, thus, resulting in the lowest possible complexity sacrificing image resolution. In order to fill the gap between those two extreme cases techniques such as Phased Sub-arrays (PSA) [21] and Sparse Arrays [22] have been proposed. Designers should be very careful while selecting the kind of the transducer, the beamforming method and the fundamental frequency especially when designing point of care systems, where the power and the space provided are limited.

D. Point-of-Care Ultrasound Devices.

Over the last century an inclination towards personalized health care and point of care monitoring has been observed. A vast part of earth's population does not have access or

cannot afford the high priced monitoring modalities. In this fashion numerous point-of-care ultrasound devices have been proposed for a wide variety of disease prognosis, diagnosis and management applications [23][24]. In ultrasound medical imaging one can distinguish two major categories of point of care devices: a) portable b) and wearable ultrasound systems. Most of these systems are based on Field Programmable Gate Arrays (FPGAs) and Digital Signal Processors (DSPs) where compact size and power dissipation are of great importance.

In the former category, many devices have been proposed and are extensively used in hospitals by trained staff. Additionally, PC based systems have been reported. Recent advancements in the field lead to the integration of ultrasonic probes with mobile phones [23]. The latter category proposes the integration of ultrasound sensors with garment in predefined position to interrogate particular regions inside the human body. A representative system in this category proposed by A. Basak and V. Ranganathan [24] in 2013. The paper describes an ultrasonic wearable system of 3 stand-alone CMUT transducers placed in particular parts of the human body for periodic monitoring. The device is intended to capture the changes of superficial cancer prone organs.

III. PROPOSED WEARABLE SYSTEM AND MATH MODELING ALGORITHMIC STEPS

Most of the previously reported point of care systems lack of the high image quality compared to expensive and bulky machines used in hospitals. Moreover, the nature of those systems requires the presence of trained staff during the examination and as consequence real time systems are necessary. The previous real-time requirement has made the use of time-consuming 2D arrays prohibitive for such applications.

In order to address these problems we propose a wearable point of care medical multi-transducer ultrasound system. The system will be composed of an array of circular 2D array transducers (Figure 2.e). We propose the use and combination of more than one transducer with the intention to take advantage of the overlapping areas that will be formed for the betterment of the final image's quality. Additionally, the use of multiple volumetric transducers will perform the monitoring of huge organs like liver without the assistance of trained staff for thorough investigation of the desired region. We adopt the use of identical transducers and we assume that they will be capable of scanning a conical like region as the one illustrated in Figure 2.e

The architecture of the system along with the configuration of the proposed array are described here. Furthermore, an algorithmic based approach for modeling the overlapping volumes produced by the configuration in Figure 3 has been developed and presented in the next subsection. The mathematical description of the overlapped regions is necessary in order to facilitate the 3D image formation of the whole region by combining the

measurements captured from all the transducers.

A. Proposed Architecture

The transducers will be integrated into a belt and in turn the belt will be placed in the upper-left abdominal region of the patient. Figure 3 illustrates the configuration of transducers in the belt and the overlapped region (gray area) produced by two adjacent transducers.

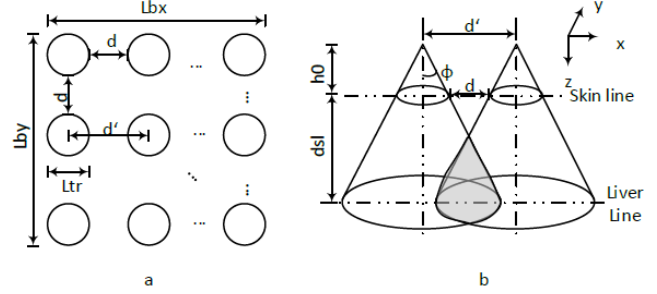

Fig.3.a) Proposed configuration of the multi-transducer system. b) Representation of field of view for two adjacent transducers and the overlapping region.

The distance (d) and the number (nxm) of the transducers that will be needed in order the system to be able to capture the whole region of interest (liver in our case) inserting the minimum possible complexity can be calculated from the formulas 1 and 2 under the restriction described in equation 3:

$$n * L_{tr} + (n-1) * d = 22.5 + a - [2 * (d_{sl} + h_0) * \tan \phi - L_{tr}] \quad (1)$$

$$m * L_{tr} + (m-1) * d = 18 + b - [2 * (d_{sl} + h_0) * \tan \phi - L_{tr}] \quad (2)$$

$$d \leq \frac{2 * (d_{sl} + h_0) * \tan \phi - \sqrt{2} * L_{tr}}{\sqrt{2}} \quad (3)$$

where n and m are the number of transducers needed in the x and y direction respectively, Ltr represents the radius of each transducer and the angle φ can be considered as half of the field of view. Lengths dsl and h0 are illustrated in the figure and lengths 22.5 and 18 are the average liver dimensions in respect to x and y direction respectively. The arbitrary constants a and b can be chosen in such a manner that the belt can be adjusted to different patient's anatomy. The above equations represent a generic scheme that can be applied for different 2D circular transducers and for a wide variety of organs and regions to be monitored.

For the rest of this paper we will assume that 6 transducer in a 2x3 array will be sufficient for monitoring the liver of the human body. The proposed architectural scheme is depicted in Figure 4. The hardware of the analog front-end is illustrated for better understanding of the integration of the transducers with the beamforming circuit. The transducers will be activated one by one in a round-robin fashion. An analog mux/demux will be necessary for the selection of the appropriate transducer each time. Thus, N channels will be

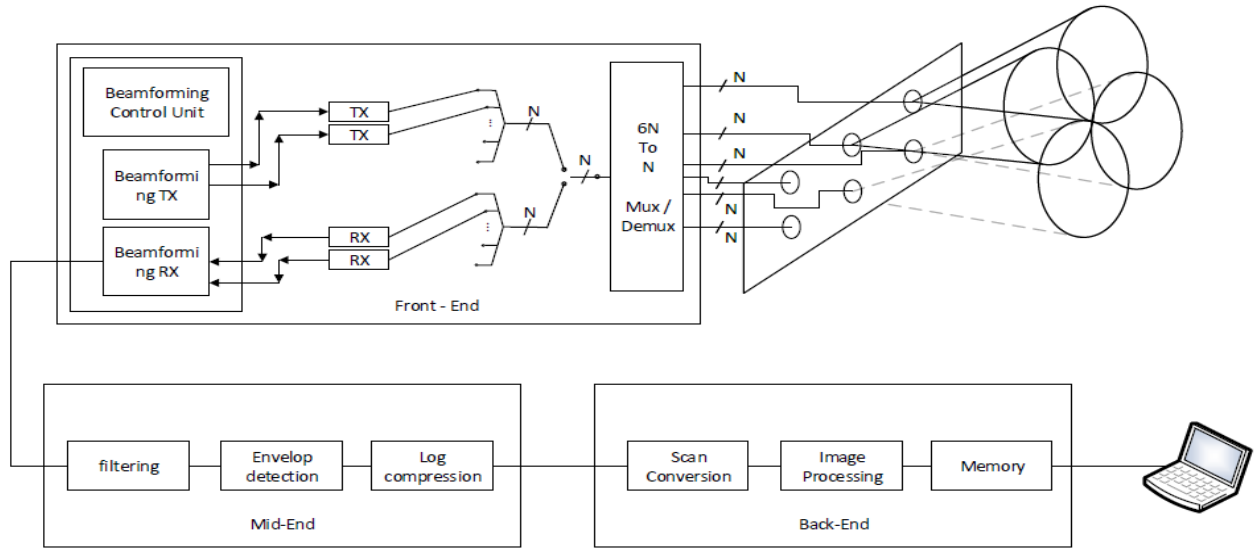

Fig. 4. General architecture of proposed system. Front-end illustrates the integration of the transducers to the board as well as the PSA technique for number of channels reduction adopted from [21]

driven to the beamforming circuit. Adopting the PSA method presented in [21] we can further reduce the active channels to k ($k \ll N$). Figure 4 represents only 2 channels. Each channel will go through filtering, envelop detection and log compression (which is classical procedure presented in [15]) and then will be summed in order to produce the outcome of each sensor through scan conversion procedure. To this point, we would like to mention that the data from the different sensors will be gathered and stored in the memory. Further image processing techniques will be applied such as registration and stitching to reach the final combined outcome of the entire 3D view of the ROI.

The basic disadvantages over the already existing systems will be the time that is needed to obtain full 3D representation of the tissue under test as well as the large memory size to store the huge amount of data.

disadvantages over the existing ones are summarized.

B. Algorithmic-based Mathematical Model for Overlapped Regions Description.

It is critical during the beamforming and the image formation procedure to have the absolute control over the area that will be monitored and to know which part of it is being captured by which sensor. Although it is out of the scope of the present work the proposal of a new beamforming scheme the overlapped volumes of the ROI are required in the registration procedure. The a-priori knowledge of the overlapped regions can lead to a significant reduction of the total time required to obtain the final volume under examination during the image processing step. We have developed a mathematical-model for the description of the overlapped regions captured by the system in Figure 4 and the algorithmic steps are presented below.

The calculation of the overlapped area can be approximated through the following algorithmic steps.

- 1) Knowing the exact position in the belt and the technical characteristics of the transducers we can estimate the depths in which new overlaps are about to introduced. In this trend we divide the axial (z) direction into layers.
- 2) We calculate all the overlapped areas in each layer as a function of the z .
- 3) Integrating from one layer to another in respect to z we obtain the overlapped volume between these layers.

We use only the first three layers in our description and we assumed that we are going to use the overlapped regions produced by the four closest transducers in the calculation of the 3D representation.

TABLE I

EXPECTED BEHAVIOR OF OUR SYSTEM COMPARED TO EXISTING ONES IN RESPECT TO CERTAIN FEATURES. SYSTEMS 1-5 REPRESENT THE CONVENTIONAL ULTRASOUND SYSTEMS THAT USE TRANSDUCERS A-E PRESENTED IN FIGURE 2

	Sys1	Sys2	Sys3	Sys4	Sys5	Proposed System
Complexity	1	2	1	3	3	3+
Field of view	1	2	2	3	3	3+
Quality of image	1	2	1	3	3	3+
Automatic scanning	no	no	no	no	no	yes
Cost	1	2	1	3	3	3+
Reliability	2	3	2	3	3	3
Robustness	2	2	2	2	2	3
Scalability	1	1	1	1	1	3
Decision support	no	no	no	no	no	yes

In table 1 the new features that such a system will introduce in the market as well as the advantages and the

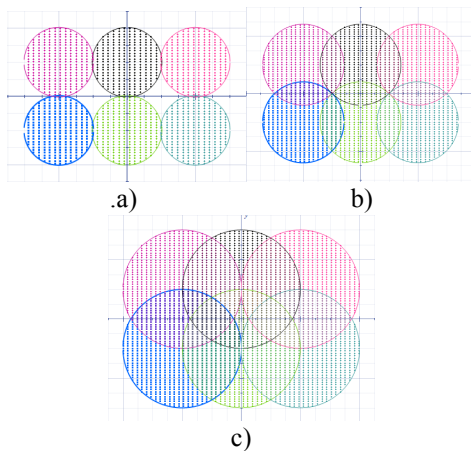

Fig.5. Areas that are formed in different depths inside the human body by the proposed 2x3 array. a) Layer 1 (in depth $d/(2*\tan\phi)$), b) Layer 2 (in depth $d/(\sqrt{2}*\tan\phi)$) and c) Layer 3 (in depth $d/\tan\phi$)

The number of overlaps that are going to be used in the procedure of image formation and volume reconstruction without sacrificing much of the complexity of the system requires further examination and depends on the application.

IV. CONCLUSION AND FUTURE WORK

In this paper a different approach of capturing ultrasound images based on a wearable multi-transducer system was proposed. We expect that such a system will present images of better quality compared to the existing ones and that will be capable of monitoring vast regions such as whole organs without the continuous assistance of a trained personnel. Especially, we anticipate alleviating the major drawback of decreased lateral resolution for deeper tissue monitoring by taking advantage of the overlapped areas. Moreover, instead of using one stand-alone sensor and manually scan the region of interest we proposed the placement of multiple sensors in predefined positions in such a way to capture the whole ROI automatically.

For future work, we keep the implementation of the proposed design and the evaluation of its performance as well as the comparison with already existing machines. Moreover, the extension of the mathematical model in order to include all the possible overlapped areas and the fully analytical description of it is our primary goal. The issues and the challenges derived from the proposed scheme are numerous, varying from the number, the type and the position of the transducer in the belt to the beamforming scheme to be adopted.

REFERENCES

- [1] J. Yang, N. DeRidder, C. Ume, and J. Jarzynski, "Non-contact optical fibre phased array generation of ultrasound for non-destructive evaluation of materials and processes," *Ultrasonics*, vol. 31, no. 6, pp. 387–394, Nov. 1993.
- [2] C. Holmes, B. W. Drinkwater, and P. D. Wilcox, "Post-processing of the full matrix of ultrasonic transmit–receive array data for non-destructive evaluation," *NDT & E International*, vol. 38, no. 8, pp. 701–711, Dec. 2005.
- [3] J. Borenstein and Y. Koren, "Obstacle Avoidance with Ultrasonic

- Sensors," *IEEE J. Robotics and Automation*, vol. 4, no. 2, pp. 213–218, 1988.
- [4] "Ultrasound evidence of sexual difference in fetal size in first trimester Outbreak of respiratory syncytial virus infection in the elderly," vol. 281, no. November, p. 9846, 1980.
- [5] PJHM Reuwer, EA Sijmons, GW Rietman, MWM van Tiel, HW Bruinse. "Intrauterine growth retardation: prediction of perinatal distress by Doppler ultrasound" *Lancet* pp. 415–418, 1987.
- [6] K. N. Malizos, M. E. Hantes, V. Protopappas, and A. Papachristos, "Low-intensity pulsed ultrasound for bone healing: an overview.," *Injury*, vol. 37 Suppl 1, pp. S56–62, Apr. 2006.
- [7] R. J. Siegel and H. Luo, "Ultrasound thrombolysis.," *Ultrasonics*, vol. 48, no. 4, pp. 312–20, Aug. 2008.
- [8] C. M. H. Newman and T. Bettinger, "Gene therapy progress and prospects: ultrasound for gene transfer." *Gene therapy*, vol. 14, no. 6, pp. 465–75, Mar. 2007.
- [9] AD. Walmsley "Applications of ultrasound in dentistry." *Ultrasound Med Biol*. vol. 14, no. 1, pp. 7–14, 1988.
- [10] J. M. Tobis, J. Mallery, D. Mahon, K. Lehmann, P. Zalesky, J. Griffith, J. Gessert, M. Moriuchi, M. McRae, and M. L. Dwyer, "Intravascular ultrasound imaging of human coronary arteries in vivo. Analysis of tissue characterizations with comparison to in vitro histological specimens," *Circulation*, vol. 83, no. 3, pp. 913–926, Mar. 1991.
- [11] O. Gehmacher, G.Mathis, A.Kopf, M. Scheier "Ultrasound imaging of pneumonia." *Ultrasound Med Biol*, vol. 21, pp. 1119-1122, 1995.
- [12] A. Sofuni, H. Iijima, F. Moriyasu, D. Nakayama, M. Shimizu, K. Nakamura, F. Itokawa, and T. Itoi, "Differential diagnosis of pancreatic tumors using ultrasound contrast imaging.," *Journal of gastroenterology*, vol. 40, no. 5, pp. 518–25, May 2005.
- [13] R. Badea and S. Ioanitecu, "Ultrasound Imaging of Liver Tumors–Current Clinical Applications," *Liver Tumors*. Alexander Julianov (ed.). InTech, pp. 75 – 102, Rijeca, Croatia, 2012.
- [14] T. Nishiura, H. Watanabe, M. Ito "Ultrasound evaluation of the fibrosis stage in chronic liver disease by the simultaneous use of low and high frequency probes." *Br J Radiol*, 78: 189–97, 2005.
- [15] M. Ali, D. Magee, and U. Dasgupta, "Signal Processing Overview of Ultrasound Systems for Medical Imaging," no. November, pp. 1–27, 2008.
- [16] S. Member, A. S. Ergun, A. Member, J. A. Johnson, K. Kaviani, T. H. Lee, and B. T. Khuri-yakub, "Transducers: Next-Generation Arrays for Acoustic Imaging," vol. 49, no. 11, pp. 1596–1610, 2002.
- [17] A. Fenster, D. B. Downey, and H. N. Cardinal, "Three-dimensional ultrasound imaging.," *Physics in medicine and biology*, vol. 46, no. 5, pp. R67–99, May 2001.
- [18] OT. von Ramm, SW. Smith, HG Jr. Pavy, "High-speed ultrasound volumetric imaging system. Part II. Parallel processing and image display" *IEEE Trans Ultrason Ferroelectr Freq Control* vol. 38 pp. 109-115, 1991.
- [19] SW. Smith, HG Jr. Pravy, OT. von Ramm, "High-speed ultrasound volumetric imaging system. Part I. Transducer design and beam steering" *IEEE Trans Ultrason Ferroelectr Freq Control* vol. 38, pp. 100-108, 1991.
- [20] G. R. Lockwood, J. R. Talman, and S. S. Brunke, "Real-time 3-D ultrasound imaging using sparse synthetic aperture beamforming.," *IEEE transactions on ultrasonics, ferroelectrics, and frequency control*, vol. 45, no. 4, pp. 980–8, Jan. 1998.
- [21] J. A. Johnson, M. Karaman, and B. T. Khuri-Yakub, "Coherent-array imaging using phased subarrays. Part I: basic principles.," *IEEE transactions on ultrasonics, ferroelectrics, and frequency control*, vol. 52, no. 1, pp. 37–50, Jan. 2005.
- [22] B. Diarra, H. Liebgott, P. Tortoli, C. Cachard, B. B. Pascal, and V. Cedex, "Sparse array techniques for 2D array ultrasound imaging," no. April, pp. 1591–1596, 2012.
- [23] A. Meir and B. Rubinsky, "Distributed network, wireless and cloud computing enabled 3-D ultrasound; a new medical technology paradigm.," *PloS one*, vol. 4, no. 11, p. e7974, Jan. 2009.
- [24] A. Basak, V. Ranganathan, and S. Bhunia, "A wearable ultrasonic assembly for point-of-care autonomous diagnostics of malignant growth." 2013 *IEEE Point-of-Care Healthcare Technologies (PHT)*, vol. 1, no. c, pp. 128–131, Jan. 2013.