

# Experimental integration of Autoregulation Unit for left ventricular assist devices in a cardiovascular hybrid simulator

G. Tortora, *Member, IEEE*, R. Fontana, L. Fresiello, A. Di Molfetta, M. Silvestri, M. Vatteroni, K. Zieliński, M. Kozarski, P. Dario, *Fellow, IEEE*, M.G. Trivella, G. Ferrari

**Abstract**—In this paper, an Autoregulation Unit (ARU) for left ventricular sensorized assist devices (LVAD) has been used with a cardiovascular hybrid simulator mimicking physiological and pathological patient conditions. The functionalities of the ARU have been demonstrating for the successful receiving and visualization of system parameters, sending of commands for LVAD speed changes, and enabling of the autonomous flow control algorithm. Experiments of speed changes and autoregulation are reported, showing the feasibility of the approach for both local and remote control of a LVAD.

## I. INTRODUCTION

Heart failure is the most increasing cause of mortality and morbidity worldwide. Furthermore, the availability of heart donors is low with relation to the growing number of patients, thus making heart transplantation the main therapy for the treatment of HF after medical treatment of cooperating causes [1]. As these often cannot be performed for several reasons, left ventricular assist devices (LVAD or, briefly, VAD) have the potential to become a viable long-term treatment option for bridging to heart transplantation or destination therapy [2]. Since their first introduction some decades ago, a large variety of VADs has been developed for treating patients affected by severe heart failure with the prospect of a future heart transplantation [3]. Recently, LVADs are evolving to be considered as long-term therapy, as well as destination therapy [4]. Much effort has been devoted worldwide with the final aim of developing therapeutic devices for reducing the patient dependence on clinical management of the implanted VAD, allowing patients to return home, improving effectively the overall life quality. Important improvements have been made in the design of VAD, used materials and fabrication [5]. However, next generation VAD requires the implementation of sensors and dedicated control system in order to be adapted to the dynamic patient conditions, automatically adjusting pump speed. Many non-invasive methods proposed so far for the prediction of dynamic patient conditions are based on complex models for estimating working parameters [6][7]. The integration of sensors is crucial in new generation VADs

Research supported by the European Commission in the framework of SensorART European Project n. 248763.

G.T., R.F., M.S., M.V., P.D. are with The BioRobotics Institute, Scuola Superiore Sant'Anna, Pisa, Italy (e-mail: n.surname@sss.up.it).

L.F., A.D.M., M.G.T., G.F. are with the Institute of Clinical Physiology, National Research Council, Rome and Pisa, Italy (e-mail: libera.fresiello@gmail.com, arianna.dimolfetta@gmail.com, gfr.ferrari@ifc.cnr.it, trivella@ifc.cnr.it).

K.Z. and M.K. are with The Nalecz Institute of Biocybernetics and Biomedical Engineering of the Polish Academy of Sciences, Warsaw, Poland.

G.T. is the corresponding author (g.tortora@sss.up.it).

in order to provide the additional parameters for improving the precision rate of implemented models. In particular, an integrated sensorized LVAD integrating flow and pressure sensors has been proposed by CircuLite GmbH (Aachen, Germany) and em-tec GmbH (Finning, Germany) in the frame of an EU project (SensorART) and experimentally tested in working conditions on a simulated scenario, as reported in [8]. Paving the way to the development of next generation systems, the integration of sensors feedback from the pump allows the design of specific units for managing the autoregulation of the pump on the basis of physiological parameters. In particular, an autoregulation unit (ARU) has been designed in order to provide the pump with a dedicated portable autonomous controller. A preliminary evaluation of the ARU functionalities has been performed using a dedicated platform including an LVAD (CircuLite, Aachen, Germany), pressure and flow sensors connected to a PC running a dedicated interface for control and data visualization, as reported in [8]. Because of the intrinsic limitations of the simulated scenario for simulating a complex system such as the cardiovascular apparatus, further testing of the ARU functionalities in a proper scenario is required in order to prove the feasibility of this approach. Testing of research preliminary outcomes on animals would be indeed the optimal scenario. Because of the ethical issues related to animal experiments, the use of a hybrid simulator, that offers the possibility of testing the LVAD in different hemodynamic conditions, is proposed for overcoming both ethical and experimental limitations. Indeed, the simulator gives the possibility to connect a real LVAD both in atrio-aortic and apical configuration and can produce a wide range of pathologies for testing LVAD performance.

This paper describes the integration and experimental tests of the autoregulation functionalities of the ARU based on the feedback of integrated sensors, in order to demonstrate the effectiveness of autonomous regulation of a VAD in a high-quality hybrid simulator scenario. The main features of both ARU and hybrid simulator and the integration between the two systems are reported in Section II. Section III describes the performed experiments. The experimental results and related discussion is reported in Section IV. At the end, conclusions are reported.

## II. MATERIALS AND METHOD

The overall integrated system presented in this paper is composed of the ARU, a PC for pump parameters visualization, the hybrid simulator with a dedicated PC for hemodynamic parameters visualization. After a brief overview of the two systems, their integration is described.

### A. Autoregulation Unit

The ARU is a FPGA-based control unit that allows the control of a LVAD. The ARU, shown in Fig. 1, behaves both as local and remote control for the VAD with additional functionalities. During operation, the ARU is connected to the sensorized pump, that provides the ARU with online parameters coming from the embedded sensors and from the pump.

The ARU is equipped with memories, allowing data storing as long as the device is worn by the VAD-implanted patient. A dedicated control unit with a display allows to visualize data and send commands to the VAD in order to vary the speed or turning the device on and off. In addition, the ARU embeds a Bluetooth module (ST, Milan, Italy) that allows wireless communication from Bluetooth monitoring devices, such as PCs or tablets, for data visualization and remote control of the VAD.

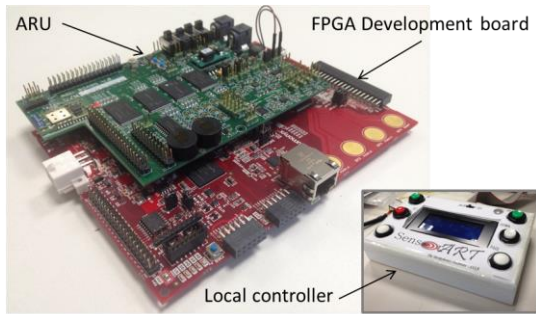

Fig. 1. ARU board and FPGA development board; the local controller (inset).

Speed variations can be performed manually both via Bluetooth and through the dedicated controller. Specific commands allow to set autonomous control of the VAD through the implemented algorithms. A schematic view of the overall scenario is reported in Fig. 2 in order to show the working flow between the patient and the specialist, that is able to manage the VAD locally or remotely for change speed settings and for activating the autoregulation algorithms of the ARU.

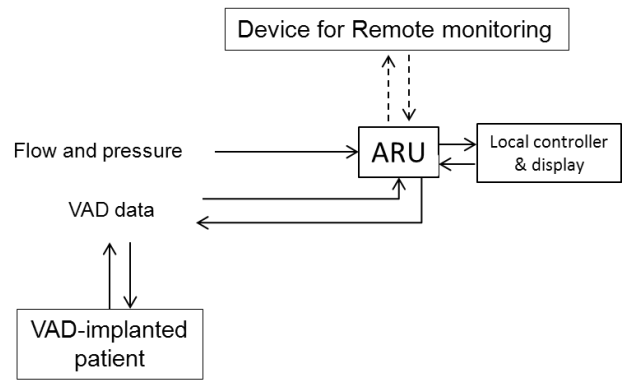

Fig.2. Schematic of the implanted VAD and workflow allowing local and remote (dotted arrows) control and monitoring.

### B. Hybrid simulator

The hybrid simulator is a hydro-numerical model of the cardiovascular system developed in LabVIEW environment at the Nałecz Institute of Biocybernetics and Biomedical Engineering. The computational part provides a representation of: left and right hearts, ascending and descending aorta, upper body, kidneys, splanchnic, lower limbs and pulmonary circulation [9]. The heart model comprises a representation of atria as passive compliances and a representation of the ventricles according to time varying elastance model [10]. The circulation is represented by a lumped parameter model based on several Windkessels organized in series and parallel.

The hydraulic part has up to four “impedance transformers” each of them including a pressure sensor (Honeywell, Columbus, OH,USA), a gear pump driven by MAXON DC motor (Maxon Motor Ag, Sachseln, Germany) and a servo controller. Data exchange between the computation and the hydraulic parts are assured in real time by A/D and D/A converters and LabVIEW Real Time Operating System (National Instruments, Austin, TX, USA) [11],[12]. The aim of the impedance transformer is to provide a real-time physical connection with the computational model. As our aim was to test the performance of a LVAD in atrio – aortic connection, two of

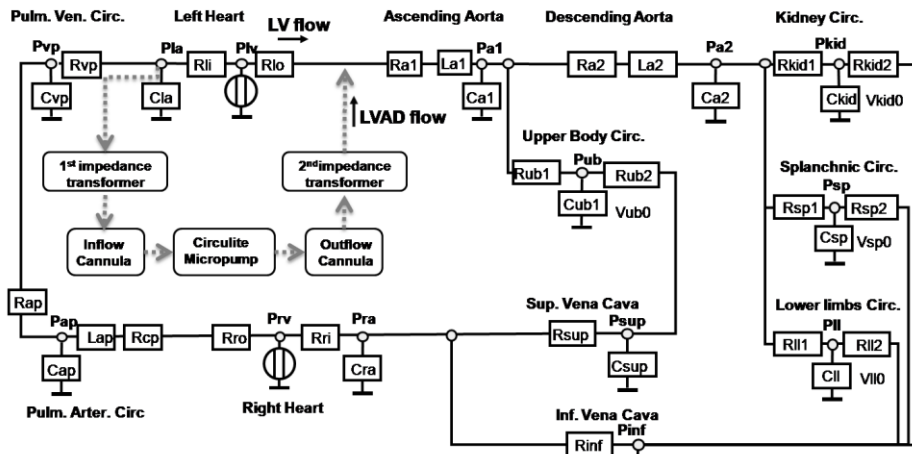

Fig.3: Block diagram of the hybrid simulator.

the four impedance transformers were used. One impedance transformer offered a real time connection with the left atrium and was used to insert the LVAD inflow cannula, the other offered a real time connection with the ascending aorta and was used to insert the outflow cannula, as shown in the block diagram of Fig. 3.

The fluid used for the hydraulic part was a mixture of glycerol and water assuring a fluid viscosity of 3.6 Pa·s similar to blood.

### C. System integration

The scope of this work is the testing of the autoregulation functionalities of the ARU integrated with a hybrid simulator. In particular, the output from the pressure and flow sensors integrated in the simulator have been connected to the input of the ARU in order to allow the data storing and the possibility of activation of the autoregulation algorithms. In order to measure the flow, a non-invasive clamp-on transducer (em-tec, Finning, Germany) has been used. This ultrasonic flowmeter is characterized by high accuracy and stability; and allows to measure flows between 1000 and 6000 ml/min. In this scenario, the hybrid simulator behaved like a real VAD-implanted patient with the added functionalities that all the parameters were monitored in real-time. The integrated system is shown in Fig. 2.

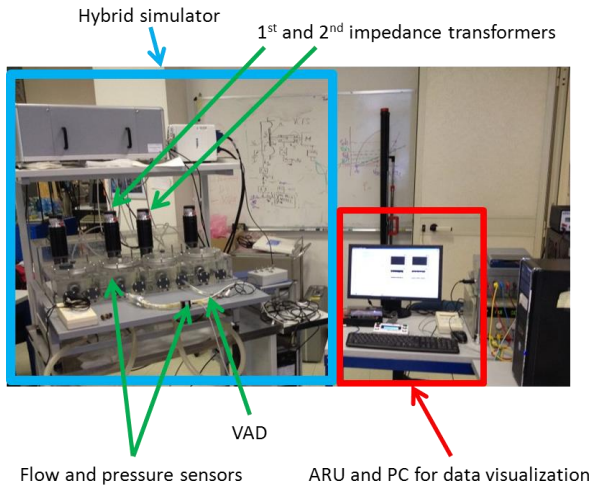

Fig. 2. Integrated system including the hybrid simulator with VAD and sensors, and the ARU.

## III. EXPERIMENTS

The experiments were aimed at:

- 1) Testing speed control, start and stop and the dynamic visualization of the LVAD data from the local controller and remote PC;
- 2) Testing the LVAD flow control in different hemodynamic conditions.

### A. Model configuration

The first step was aimed at configuring the hybrid simulator in such a way to reproduce an ischemic cardiomyopathy (ICM), condition usually characterizing LVAD patients. To this aim, the left ventricular elastance ( $E_{\max}$ ), which represents the contractile properties of the ventricle in systole, was decreased to 1 mmHg/ml. In addition, the zero pressure filling volume of the left ventricle

( $V_{lv0}$ ) was increased up to 50 ml to simulate a dilated myocardium. Similarly, the heart rate (HR) was slightly increased to 80 bpm.

### B. Experiments with stepwise LVAD speed increment

This first group of experiments was performed starting from the simulation of the ICM condition without assistance. Then the LVAD was activated and different levels of LVAD speed were tested.

The speed of the pump connected to the hybrid simulator has been changed through the local controller, after checking that the displayed parameters were matching the simulator outputs correctly. In particular, the speed of the pump has been changed through dedicated buttons of the local controller. The pump speed has been stepwise increased from 20000 to 26000 rpm. After each step, 30 seconds elapsed to monitor the adaptation of the hybrid simulator physiological parameters.

Afterwards, the remote control was activated to perform a stepwise speed decrement from 26000 to 20000 via the wireless link. Data from the sensorized pump were online collected from remote for 15 minutes.

### C. Experiments with LVAD flow control

This second group of experiments was aimed at testing the flow control of LVAD in different hemodynamic conditions.

The hybrid simulator was set to the ICM condition and the LVAD was activated. The flow control was set to 2 l/min and left free to reach the desired flow value.

Then the peripheral resistance of hybrid simulator was changed: starting from a default value of 1 mmHg·s/ml the peripheral resistance was at first increased up to 1.5 mmHg·s/ml and then decreased to 0.5 mmHg·s/ml.

In order to test the autoregulation algorithms to the desired flow level, a proportional integrative control implemented in the ARU has been used for setting the desired flow, and directly change the pump speed continuously as long as the clinician decides to manually change the VAD speed.

## IV. RESULTS AND DISCUSSION

The hybrid simulator platform has been exploited in order to assess the functionalities of the system when monitoring current parameters, controlling the LVAD speed, and enabling autoregulation control algorithms. In this conditions, experiments of speed control and flow control have been performed.

The results of speed experiments are reported in Fig. 5, where the physiological adaptation of the hybrid simulator to consequent speed changes is shown. Different speed values have been successfully set both through the local controller and the wireless link. Physiological parameters from the simulator, such as the LVAD Flow, Left ventricle Flow (LV Flow) and aortic pressure (Pa1) are shown together with the LVAD speed. Starting from the ICM condition, the VAD cannulas were unclamped keeping the VAD switched off. As the VAD has no valves a back flow from the aorta (2<sup>nd</sup> impedance transformer) to the left atrium (1<sup>st</sup> impedance transformer) was observed, resulting in an increment of LV flow with a simultaneous decrease of Pa1. Then the VAD was activated and its speed was progressively increased. This resulted in a decrement of LV flow (from 3.8 l/min at

VAD off to 2.3 l/min at 26000 rpm) and in an increment of both diastolic/systolic Pa1 pressure (from 54/80 mmHg at VAD off to 72/90 at 26000 rpm).

Results from the second set of experiments, concerning the autoregulation flow control are shown in Fig. 6. As changes of systemic blood pressure are commonly observed on patients within even a single day, in the present experiment a change of peripheral resistance was performed using the hybrid simulator. After the activation of the algorithm, the ARU automatically smoothly adjusted the flow for keeping at a constant value. Afterwards, the peripheral resistance was suddenly increased, then decreased and finally set to its baseline value again. This resulted in a strong change of diastolic/systolic Pa1: from a baseline value of 66/82 mmHg, to 88/99 mmHg at the higher resistance, to 40/59 mmHg at the lower resistance. Without the autoregulation flow control, such a change of afterload would have induced a consequent change of flow provided by the device. In the present case, the implemented autoregulation flow control allowed to keep the LVAD flow to the desired value of 2 l/min all along the experiment, despite the change of working condition of the system.

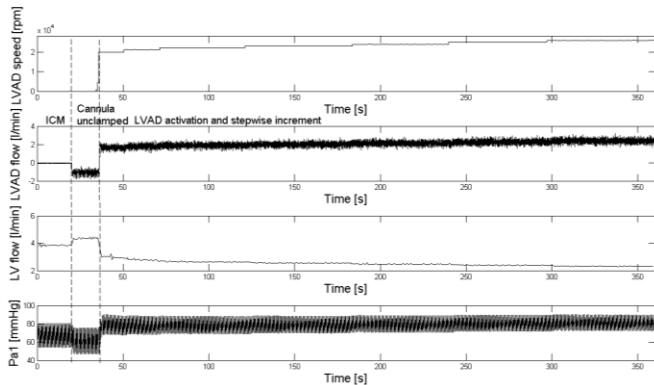

Fig. 5. Results from the speed variations experiments.

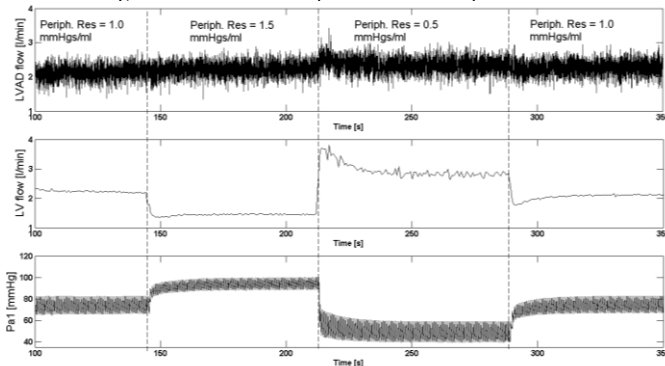

Fig.6. Results from the flow control experiments.

## V. CONCLUSION

In this paper, the ARU device for the autoregulation and control for left ventricular assist devices has been used with a cardiovascular hybrid simulator mimicking physiological and pathological patient conditions. The possibility to change LVAD settings both through a local controller and via wireless has been successfully demonstrated. The autoregulation flow control has been also demonstrated to be effective in the autonomous control of a sensorized LVAD through a portable device in a scenario of improved

implanted patient life quality.

The added value of the use of a hybrid simulator is the possibility to extensively test the ARU functionalities as in a real cardiovascular system, without the need of exposing the system to an *in vivo* experimental session. This indeed allows to slightly refine the system overall behavior (i.e. the weight that autoregulation algorithms should have in a real scenario) and in order to prepare future *in vivo* experimental sessions, when the experiments will be performed with a sensorized VAD integrating pressure and flow sensors.

## ACKNOWLEDGMENT

The authors wish to thank CircuLite GmbH (www.circulite.net) and em-tec GmbH (www.em-tec.com) for providing the pump and the flow sensor.

## REFERENCES

- [1] A.H. AlOmari, A.V. Savkin, M. Stevens, D.G. Mason, D.L. Timms, R.F. Salamonsen, N.H. Lovell, "Developments in control systems for rotary left ventricular assist devices for heart failure patients: a review", *Physiol. Meas.* 34, 2013.
- [2] Ž. Sutlić, Z. Čeko, D. Barić, I. Rudež, D. Unić, M. Planinc, and D. Jonjić, "Overview of New Mechanical Circulatory Support Devices", *Rad Hrvat Akadem Znanj Umet Med Znan*, vol. 509, pp. 123-132, 2011.
- [3] S. Westaby, M. Siegenthaler, F. Beyersdorf, M. Massetti, J. Pepper, A. Khayat, R. Hetzer, and O. H. Frazier, "Destination therapy with a rotary blood pump and novel power delivery," *Eur J Cardiothorac Surg*, vol. 37, pp. 350-356, 2010.
- [4] T. Hrobowski and D. E. Lanfear, "Ventricular assist devices: is destination therapy a viable alternative in the non-transplant candidate?", *Curr Heart Fail Rep*, vol. 10, pp. 101-107, 2013.
- [5] S. Agarwal, K.M. High, "Newer-generation ventricular assist devices", *Best Practice & Research Clinical Anaesthesiology*, 26, 117-130, 2012.
- [6] H.A. Khalil, D.T. Kerr, M.A. Franchek, R.W. Metcalfe, R. Benkowski, W.E. Cohen, E. Tuzun, B. Radovancevic B, O.H. Frazier, K.A. Kadipasaoglu, "Continuous flow total artificial heart: modeling and feedback control in a mock circulatory system" *ASAIO J.* 54 249-55, 2008.
- [7] A.H. AlOmari, A.V. Savkin, P. Ayre, E. Lim, D.G. Mason, R.F. Salamonsen, J.F. Fraser, N.H. Lovell, "Noninvasive estimation and control of inlet pressure in an implantable rotary blood pump for heart failure patients", *Physiol. Meas.* 32 1035-60, 2009.
- [8] A. Verbeni, R. Fontana, M. Silvestri, G. Tortora, M. Vatteroni, M.G. Trivella, P. Dario, "An innovative adaptive control strategy for sensorized Left Ventricular Assist Devices", *IEEE Transactions on Biomedical Circuits and Systems*, 2014.
- [9] L. Fresiello, K. Zielinski, S. Jacobs, A. Di Molfetta, K.J. Palko, F. Bernini, M. Martin, G. Ferrari, M.G. Trivella, K. Górczyńska, M. Darowski, B. Meyns, M. Kozarski, "Reproduction of continuous flow lvad experimental data by means of a hybrid cardiovascular model with baroreflex control", *Artificial Organs*, 2013.
- [10] K. Sagawa, L. Maughan, H. Suga, K. Sunagawa, "Cardiac Contraction and the Pressure-Volume Relationship", *Oxford University Press, New York*, 1988.
- [11] M. Kozarski, G. Ferrari, K. Zielinski, K. Górczyńska, K.J. Palko, A. Tokarz, M.A. Darowski, "A New Hybrid Electro-Numerical Model of the Left Ventricle", *Computers in Biology and Medicine*, 38(9), 979-989, 2008.
- [12] M. Kozarski, G. Ferrari, K. Zielinski, K. Górczyńska, K.J. Palko, L. Fresiello, A. Di Molfetta, M. Darowski, "A hybrid (Hydro-Numerical) Cardiovascular Model Application to Investigate Continuous-Flow Pump Assistance Effect", *Biocybernetics and Biomedical Engineering*, 32(4):77-91, 2012.